

Training Module



Walk-in-Cooler/ Walk-in-Freezer Repair & Maintenance



India 2017

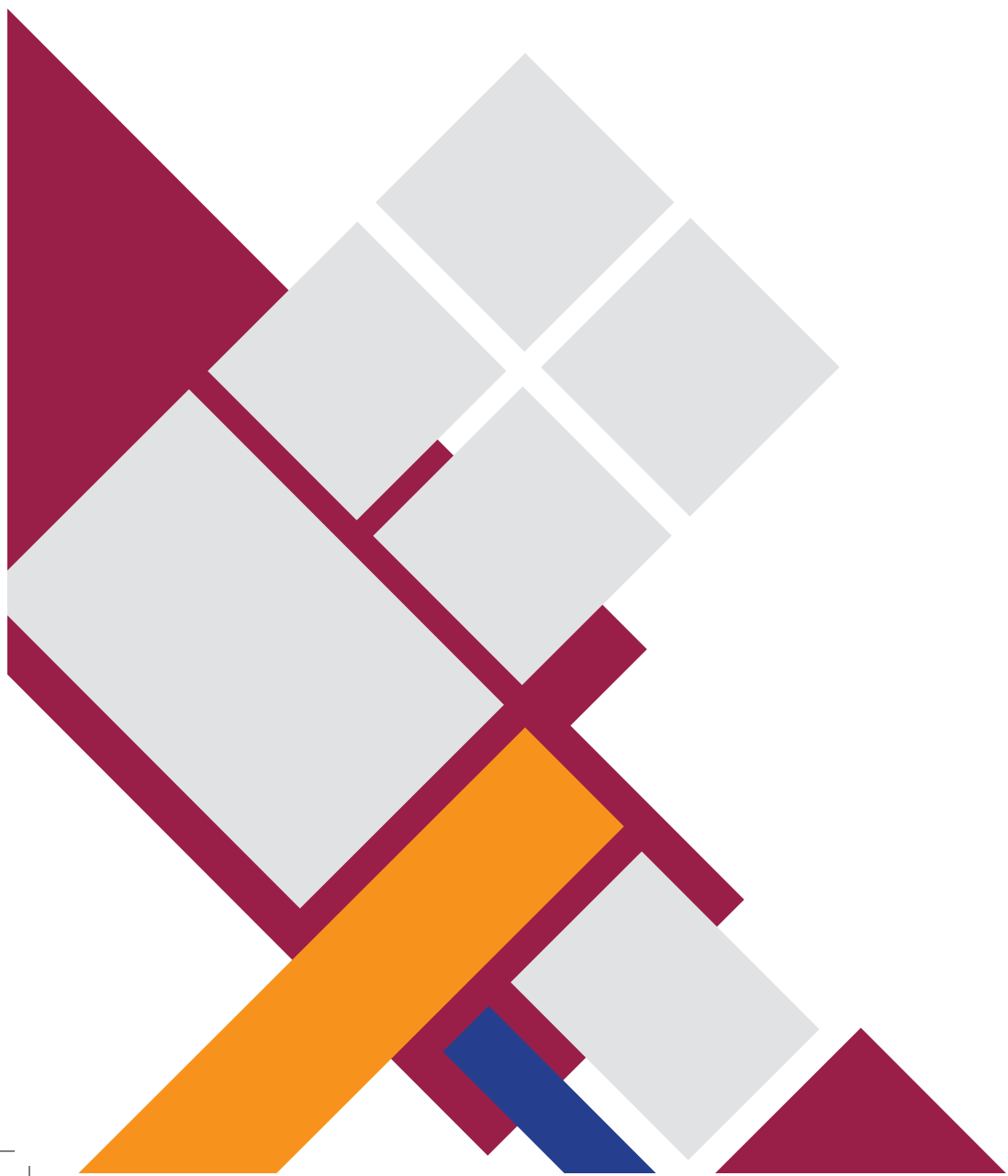

Training Module
**Walk-in-Cooler/
Walk-in-Freezer**
Repair & Maintenance

India 2017



Acknowledgements

Authored By:

1. National Cold Chain & Vaccine Management Resource Centre (NCCVMRC), NIHFW, New Delhi.
2. National Cold Chain Resource Centre (NCCRC), SHTO, Pune.

Advisors:

1. Prof. J.K Das, NIHFW
2. Dr. Pradeep Haldar, MoHFW
3. Dr. M.K. Aggarwal, MoHFW
4. Prof. Sanjay Gupta, NIHFW
5. Dr. Satish Gupta, UNICEF, ICO
6. Dr. Bhrigu Kapuria ,UNICEF, ICO

List of Contributors:

1. Er. Yogesh Bhamare, NCCRC, Pune
2. Er. Hitesh Kumar, NCCVMRC, NIHFW, New Delhi
3. Mr. Durgesh Deshmukh, NCCRC, Pune.
4. Dr. Akshaya Kumar Mishra, UNICEF, ICO
5. Er. Dheeraj Bhatt, UNICEF, ICO
6. Dr. Mainak Chatterjee, NCCVMRC, NIHFW, New Delhi
7. Mr. Harkesh Singh, NCCVMRC, NIHFW, New Delhi
8. Mr. Rajesh Kumar, NCCVMRC, NIHFW, New Delhi
9. Mr. Shashank Savita, NCCVMRC, NIHFW, New Delhi
10. Cold Chain Officers of all states and UTs
11. National Resource Pool Cold Chain Technicians



ACRONYMS

Ø =Phase
 Ω=Ohm
 a = absolute pressure
 AMF = Auto Mains Failure
 amp = ampere
 AC= Alternate Current
 Atm = atmosphere
 A.N.M. = Auxiliary Nurse Midwife
 BTU = British thermal unit
 cal = calorie
 CCE = Cold Chain Equipment
 CHC = Community Health Center
 CO₂ = Carbon dioxide
 CFC = Chlorofluorocarbons
 CSCR = Capacitor Start Capacitor Run
 CSIR = Capacitor Start Induction Run
 °C = degree Celsius
 °F = degree Fahrenheit
 cm = centimeter
 DC=Direct Current
 DF = Deep Freezer
 DVS = District Vaccine Store
 EPI = Expanded Programme on
 Immunization
 Ft. = foot
 g = gauge pressure/gram
 GWP = Global Warming Potential
 h = hour
 HC = Hydro Carbon to be add
 HCFC = Hydro chlorofluorocarbons
 HFC = Hydro fluorocarbon
 HQ = Head Quarter
 HST = High Starting Torque
 ILR = Ice Lined Refrigerator
 In = inch
 ISI = Indian Standards Institute
 j = joule
 k = Kelvin
 kcal = kilo calorie
 Kg = kilogram
 Kpa = Kilo Pascal
 Kp = Kilopound
 KWh = kilowatt hour
 lb = pound
 LMS = Line Mains Start
 LST = Low Starting Torque
 m = meter
 mb = millibar
 MCB = miniature circuit breaker
 mmHg = millimeter mercury column
 MO = Medical Officer
 mwg = meter water gauge
 N₂ = Nitrogen
 NTC =Negative Temperature Coefficient
 ODP = Ozone Depletion Potential
 OEM = Original Equipment Manufacturer
 Pa = Pascal
 PC = Personal computer
 PHC = Primary Health Center
 psi = pound per square inch
 PSC = Permanent Split Capacitor
 PTC = Positive Temperature Coefficient
 RSIR = Resistance Start Induction Run
 s = Second
 SI = System International
 TEV = Thermostatic Expansion Valve
 TMD = Temperature Monitoring Device
 TP = Terminal plug
 UIP = Universal Immunisation Programme
 UV-B = Ultraviolet - B
 VAC = Vacuum
 Volt = voltage
 W = watt
 WIC = Walk in Cooler
 WIF = Walk in Freezer
 WHO = World Health Organisation



CONTENTS

Introduction	01
A. Effective Vaccine Store	07
B. WIC/WIF & its Components	25
C. Sample block diagram sequence for interconnection of WIC/WIF components	61
D. DG Set Standby Power Supply & Servo Voltage Stabilizer	85
E. Spare parts and Tool kit	115
F. Annexures	123





Introduction

Immunization is one of the most well-known and effective methods of preventing childhood diseases. With the implementation of Universal Immunization Programme (UIP), significant achievements have been made in preventing and controlling the Vaccine Preventable Diseases (VPDs). Immunization has to be sustained as a high priority to further reduce the incidence of all VPDs, control measles, eliminate tetanus and eradicate poliomyelitis.

India has one of the largest Universal Immunization. Program (UIP) in the world in terms of quantities of vaccines used, number of beneficiaries (27 million infants and 30.2 million pregnant women) covered, geographical spread (29 States and 7 Union Territories) and manpower involved. India spends more than Rs. 2000 crores every year in immunization program (including polio eradication) to immunize children against vaccine preventable diseases including polio eradication program.

Under UIP, all the children in the entire country are protected against the 12 deadly Vaccine Preventable Diseases (VPD) namely Tuberculosis, Diphtheria, Tetanus, Pertussis, Polio, Measles, Pneumonia, Diarrhoea, Meningitis, Rubella, Japanese Encephalitis & Hepatitis B. Immunization services are provided through vast health care infrastructure consisting of district hospitals, community health centers (CHC), primary health centers (PHC) and sub-centers.

One of the important elements for improving the immunization is cold chain and vaccine logistics management which is backbone of immunization programme. Cold Chain and vaccine management are the left and right hands of immunization programme.



What is Cold Chain?

Cold Chain is a system of storing and transporting vaccines at recommended temperatures from the point of manufacture to the point of use. The key elements of the cold chain are:

Personnel to manage vaccine storage and distribution (vaccine and cold chain handler at each point)

Equipment to store and transport vaccine and to monitor temperature

Procedures to ensure that vaccines are stored and transported at appropriate temperatures

As a Cold chain technician you should ensure that cold chain equipment is functional, storage temperatures are correctly maintained and recorded



Vaccine sensitivities

All vaccines are heat sensitive and are damaged by temperatures more than +8 degree Celsius, whether they are exposed to a lot of heat in a short time (e.g., as a result of keeping vaccine in a closed vehicle in the sun) or a small amount of heat over a long period (e.g., as a result of the frequent door opening of WIC/WIF).

Reconstituted BCG, measles and JE vaccines are the most heat and light sensitive. Since these live vaccines do not contain preservatives, there is risk of contamination leading to Toxic Shock Syndrome and, therefore, they should be used within 4 hours of reconstitution (4 hours for JE vaccine). These light sensitive vaccines are supplied in amber-coloured vials.

DPT, TT, Hep B, IPV and Penta vaccines are freeze sensitive i.e. they lose their potency if frozen. BCG, Measles and JE vaccines are light sensitive. The physical appearance of the vaccine may remain unchanged even after it is damaged. However, the loss of potency due to either exposure to heat or cold is permanent and cannot be regained.

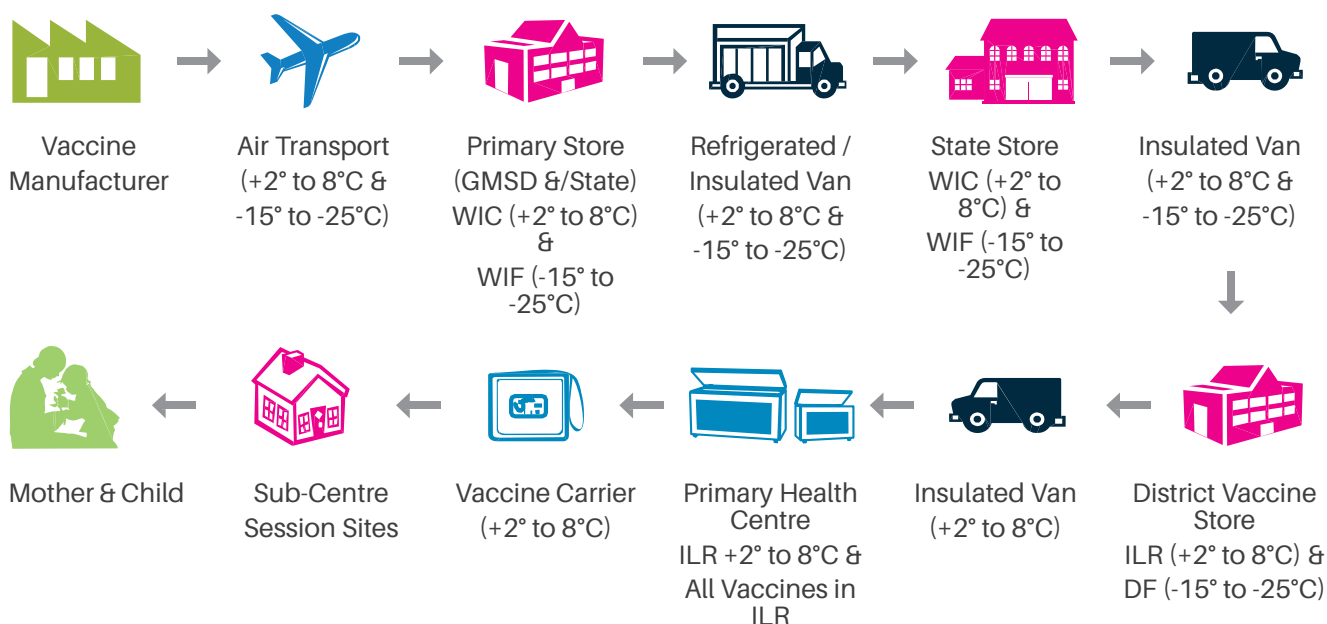

Walk-in-Coolers/ Walk-in-Freezers

Cold rooms have been in operation throughout the country since inception of the Universal Immunization Program (UIP) in 1985. WIC/Fs are mostly installed in Government Medical Store Depots (GMSD) (primary) and State, Regional/ Divisional (intermediate) vaccine stores. The number and capacities of these vaccine stores have expanded gradually to meet the need of the UIP. Dedicated staffs are deployed to manage, maintain and repair these WIC/Fs. A need was felt to offer these mechanics and technician with comprehensive technical information and guidelines to support their day to day work. Specific trainings to these staff on management, maintenance and repair of WIC/Fs are underway.

This handbook has been prepared as a standard document for refrigeration technicians/mechanics who are entrusted to maintain and repair of cold rooms/freezer rooms in their areas. It offers detailed technical guidance on WIC/F and provides reference material for components of cold/freezer rooms. Handbook may also serve as a guide for WIC/F repair and maintenance training.

The cold rooms in India have been sourced from various Manufacturers. While it is not possible to provide comprehensive information for all the models in use. The information is by and large applicable to most of the models used for immunization programme.



Notes

.....

.....

.....

.....

.....

.....

.....



This handbook tries to cover following aspects....

- Planning for Effective Vaccine Stores deals with the organization and space planning of the vaccine store, standards of the store buildings, space planning and introduces the concepts of vaccine safety as applicable to WIC/F.
- Components of cold rooms, Technical specification of the cold rooms.
- Installation & General Preventive maintenance for the WIC/WIF & its interfacing equipment like DG sets, Servo Stabilizes. The maintenance part is mainly related with WIC/WIF & DG Set/Battery.
- Troubleshooting part, which provides solutions to common problems and scenarios a refrigeration mechanic might encounter while looking after the cold rooms.
- Lists of fast moving spare parts & essential tools that is required for WIC/ WIF maintenance.

Notes



Effective Vaccine Store





Learning Objectives

A cold store meets its objective and delivers the efficient service if it is planned well; equipments are installed as per standard guidelines; there is logical workflow between various parts of cold store; standard operating procedures are followed and contingency plan is available to safeguard vaccines in case of emergency. This chapter covers these aspects in detail.

Space planning (How to plan a vaccine store)

Standard sizes of the cold rooms

Choosing store site and basic building standards

Vaccine Safety



1. Space planning

1.1 Planning vaccine store

Vaccine stores should be planned keeping the perspective of having:

- Vehicle loading bay to load and unload vaccine.
- Adequate floor space to accommodate the refrigeration equipment including cold rooms.
- Dry (protected from heat, water and sunlight) floor space for storage of diluents, droppers and syringes.
- Cool floor space (not to exceed 25°C) for unpacking and packing of vaccine.
- Storage space with easy retrieval of packaging material.
- Store keeper's office with full view access to entire facility and with provisions of protected filing of important documents.



1.2 Vehicle loading bay

The detailed design of a vehicle loading bay is governed by the size and type of vehicle used. Consideration should be given to:

1. **Access:** The loading bay and the route to it must be planned to allow easy access for the largest vehicle used.
2. **Security:** Vaccines are high cost value. The loading bay area should therefore be visible from the storekeeper's office to ensure security.
3. **Weather protection:** A loading bay should preferably have a projecting canopy to protect workers, vehicles and vaccines from sunlight, rain or snow during loading and unloading.
4. **Loading dock:** Delivery vans can be loaded from ground level. However, it is more convenient to load and unload vehicles from a loading dock that is at the same level as the floor of the vehicle. This makes it possible to use a trolley to wheel vaccine into the vehicle. A raised loading dock should be between 1.2 and 1.4 metres above the vehicle parking area. Ideally, it should be built to match the height of the delivery vehicle.
5. **Special requirements for refrigerated vehicles:** Some states have refrigerated vehicles to distribute vaccine from the primary store to intermediate stores. A refrigerated vehicle must be fitted with a temperature logger; there should be a weatherproof electrical outlet to power the vehicle's refrigeration unit during loading and unloading operations; and there should be sufficient space to store delivery crates if these are used in place of cold boxes.



1.3 Refrigeration Equipment Area

The refrigeration equipment area should be laid out so that diluents and OPV droppers can be stored nearby on easily accessible shelves close to the cold store. **Each vaccine manufacturer supplies diluents that are only compatible with its own vaccine.** It is very important that diluents be systematically stored and subjected to the same rigorous stock control procedures as the vaccines with which they are intended to be used. Experience shows that good control of diluents stock is more likely to be achieved when it is stored close to the vaccine with which it is to be used.

The information in this section assumes that prefabricated cold stores with twin packaged refrigeration units are in use. Figure 1 shows typical layouts and clearances for cold stores in a range of sizes from 5 m³ to 40 m³. Figure 2 shows the layout and clearances required around WIC/F.

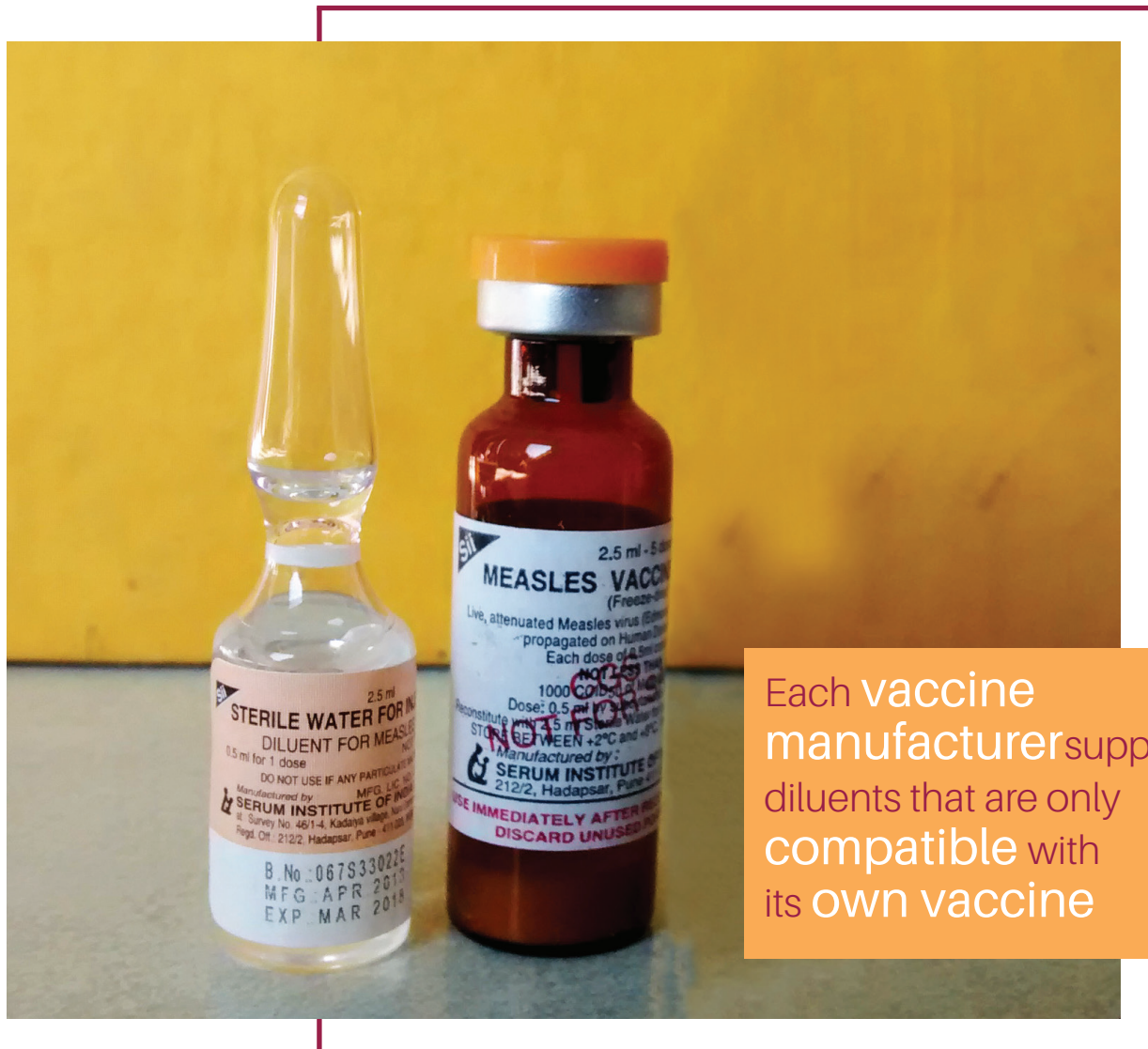

Figure 1: Standard sizes of cold rooms

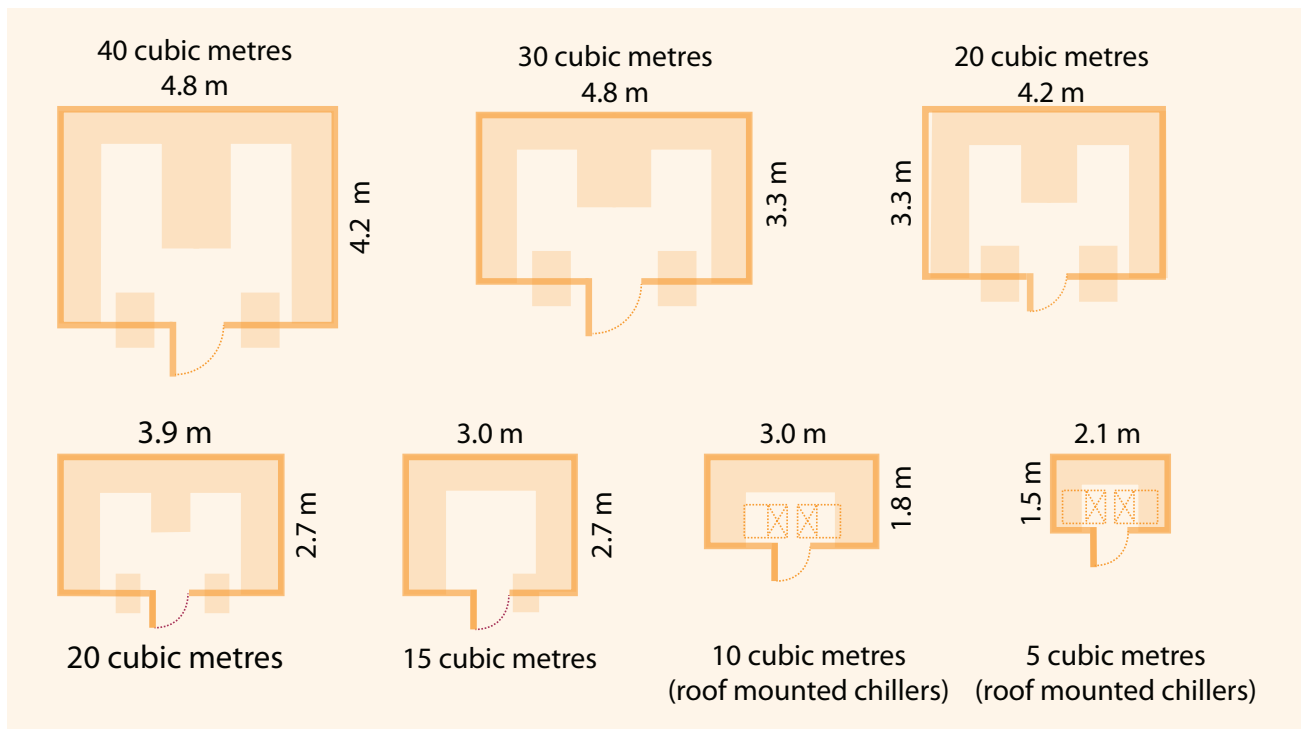

Figure 2: Typical cold room installation layout (1)

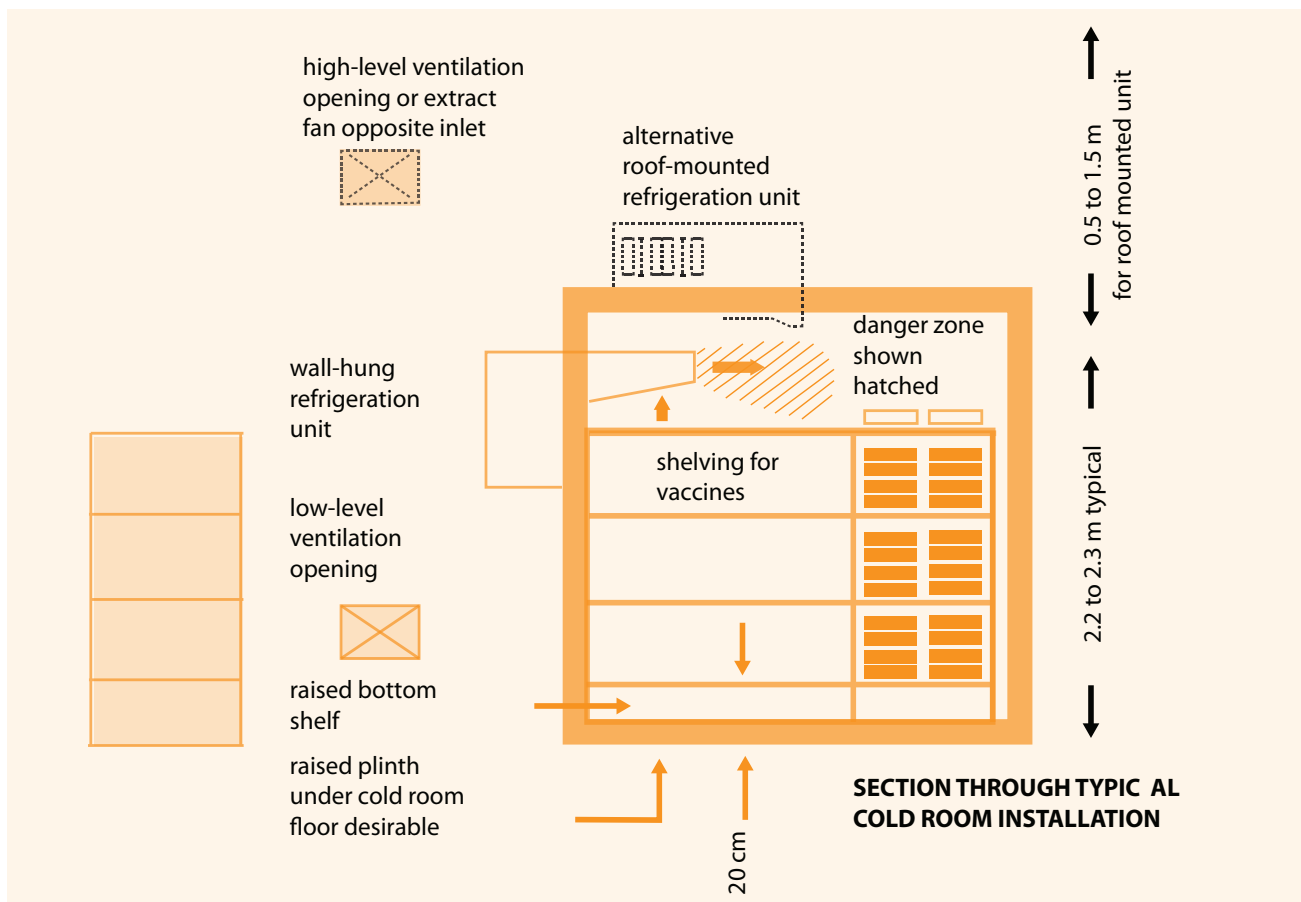
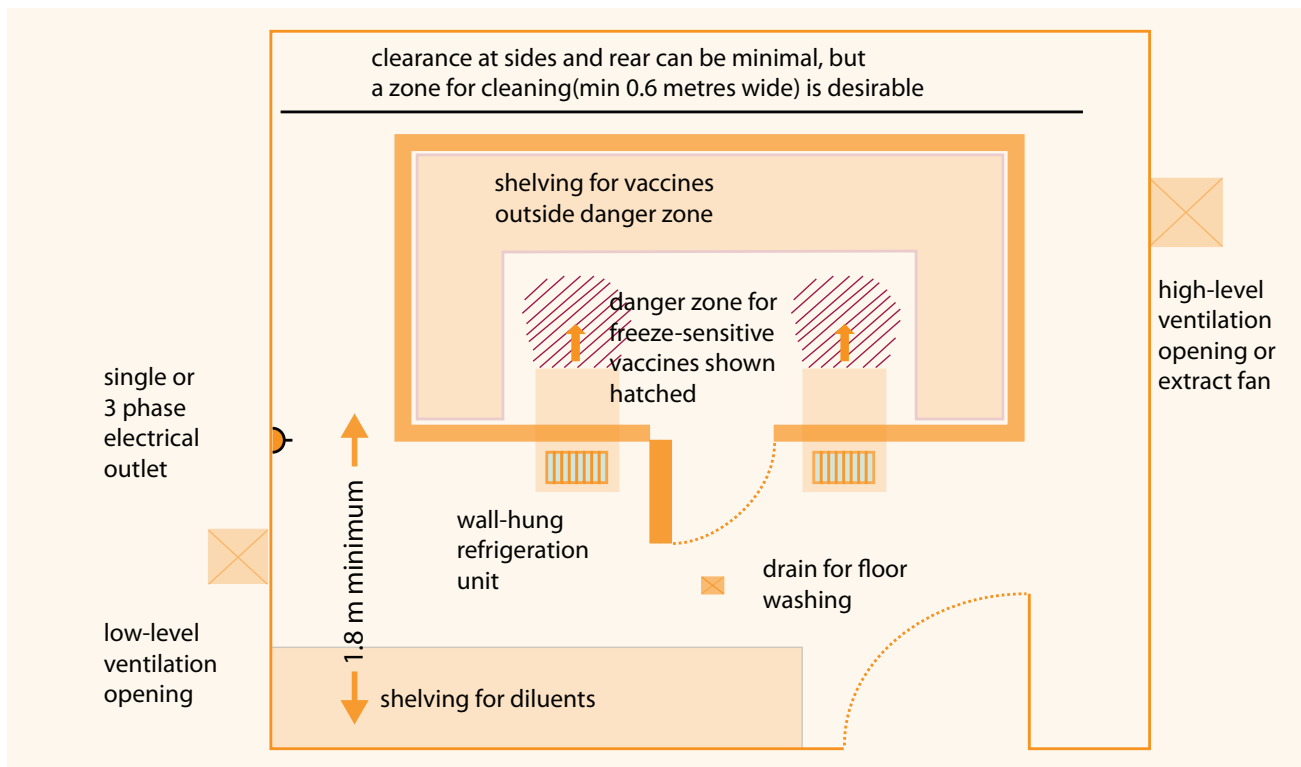

Figure 3: Typical cold room installation layout (2)



The internal height of WIC/WIF where stock is moved by hand should not exceed 2.3 metres. This limit ensures that the vaccine on the top. Shelves is accessible without the use of steps. WIC/WIF should be planned so that they accommodate the greatest possible length of shelving, taking into account the locations of the entrance door and the refrigeration units. A square plan is not necessarily the most space efficient, especially in smaller units.

Vaccine boxes should be arranged so that there is free movement of air between the vaccine packages, which should be stored about 5 cm away from the walls of the room. This allows air movement behind the stock and ensures an even temperature. Slatted shelving also assists air circulation and is therefore preferable to solid shelving.

1.4 Vaccine packing area

Following figure is a schematic layout for a typical vaccine packing area. The size of the space required depends on the maximum daily transaction and the number of staff employed. The packing area should connect to a direct route between the WIC/F and the vehicle loading area. It must not form part of a main circulation route because it has to be kept cool possibly by airconditioning and secure. Vaccine packing involves a number of linked activities, all of which should be accommodated in the same space.

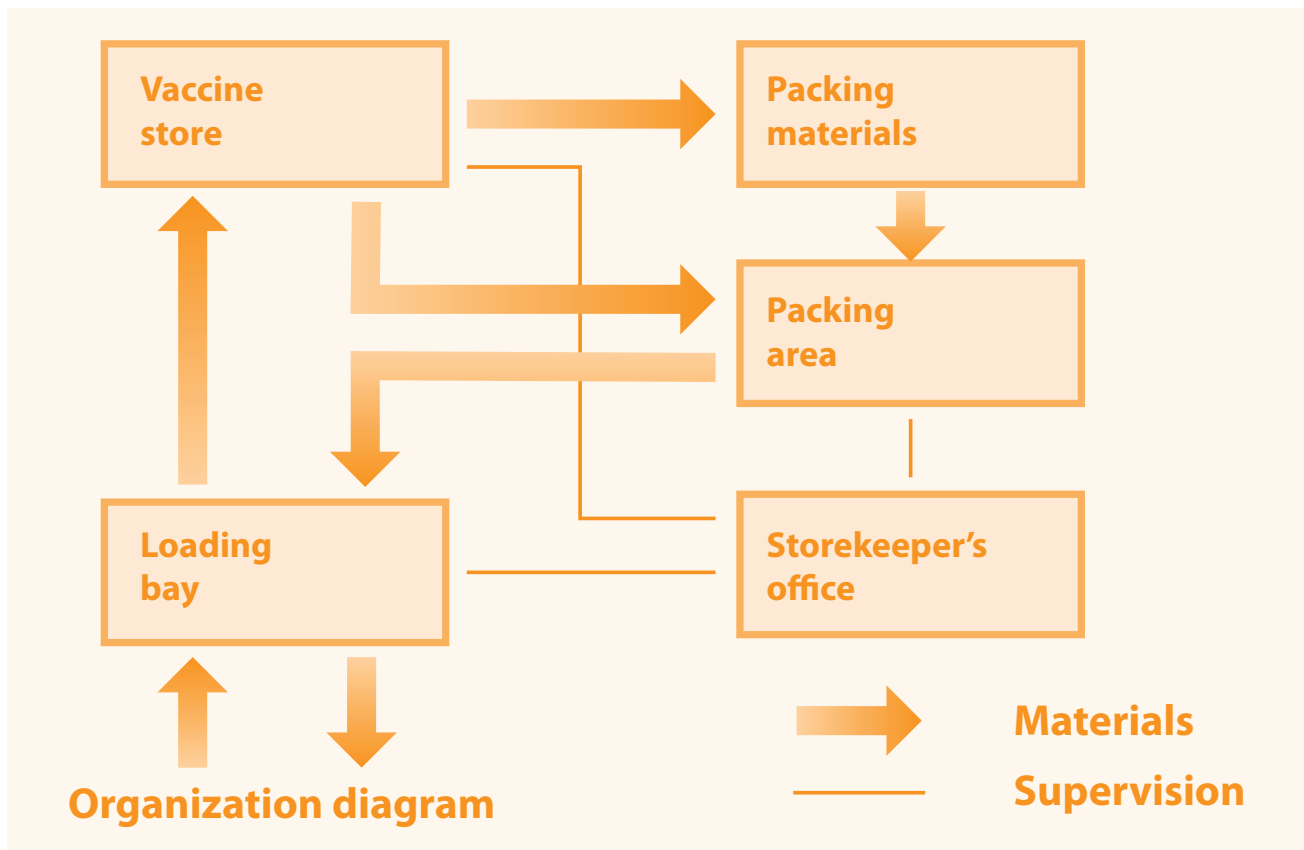
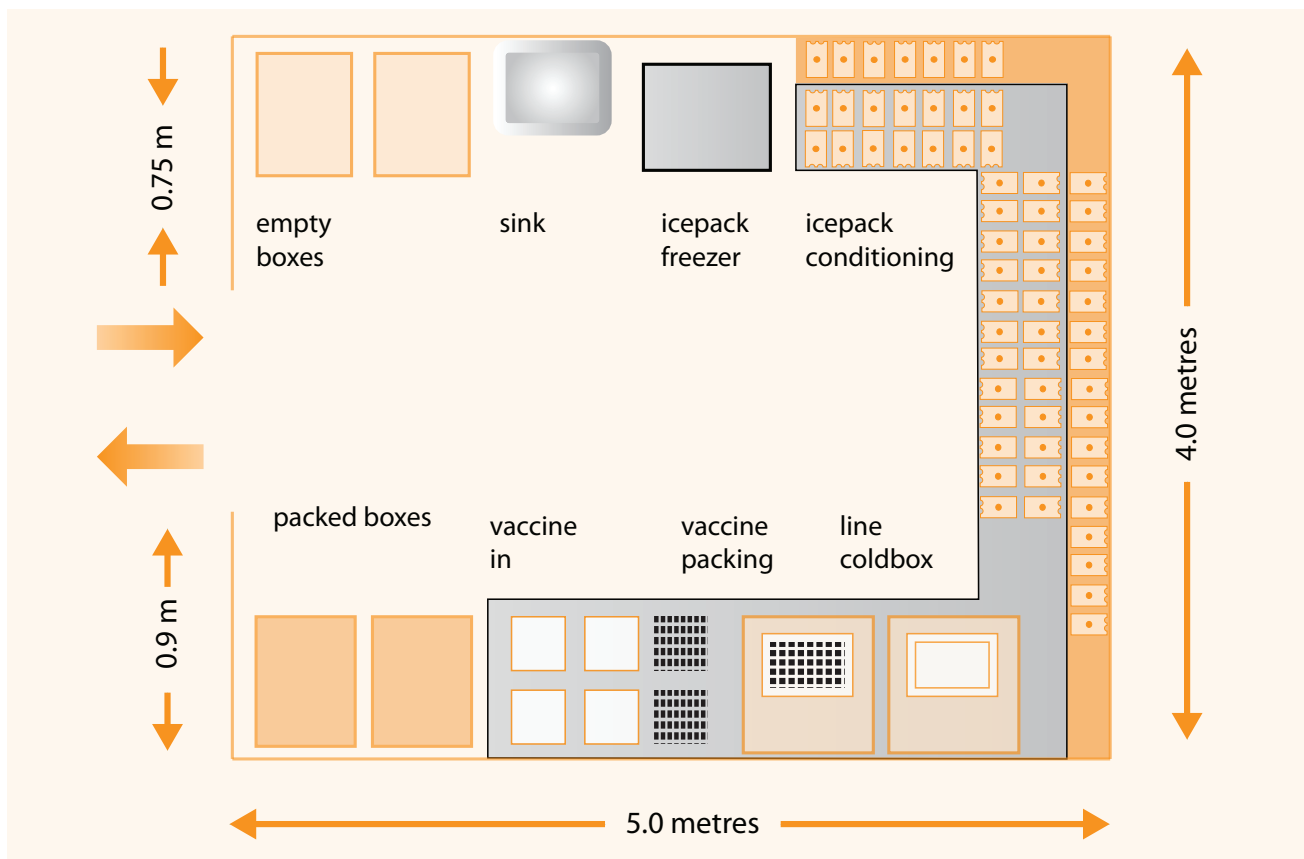

Figure 4: Store floor plan and layout of packing area





The packing area should be laid out so as to encourage a logical flow of work. Vaccines should be moved as little as possible in order to minimize the risk of breakage. There should be a sink in the packing area for hand washing and provision for hygienic hand drying.

1.5 Choosing a site

The checklist below outlines the main steps in the process of site selection.

1. Determine the size of the store and its access requirements:

Using the information given above, calculate the floor area required for the vaccine store and the size of delivery vehicles.

2. Review potential sites:

Consider the following alternatives.

- a. Space in a government warehouse or other government building that can be adapted for the purpose.
- b. Commercial warehouses that can be purchased or rented.
- c. Empty sites that can be developed.

3. Assess natural hazards:

Consider the following.

- a. Are any of the potential sites at particular risk from natural hazards, e.g. tidal surges, storms or earthquakes?

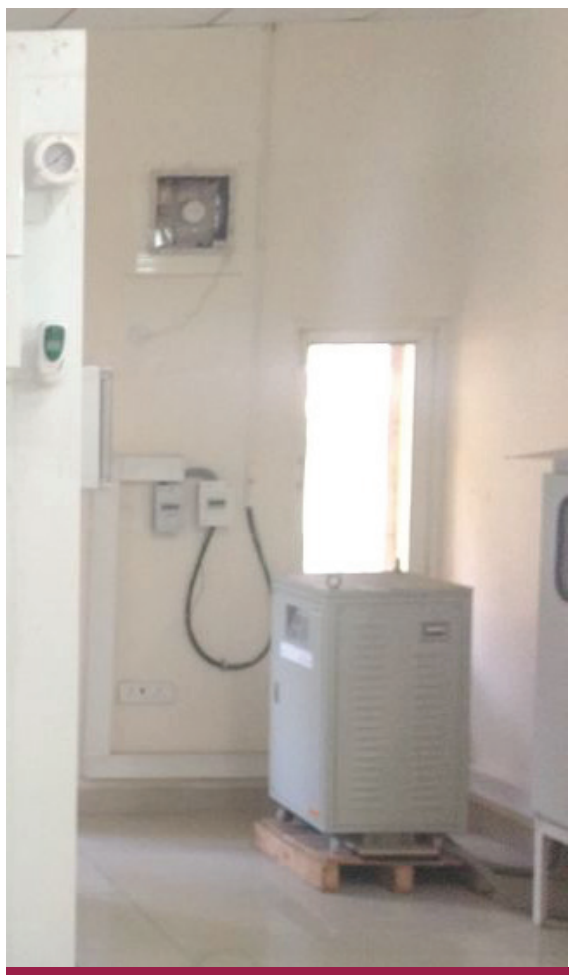

- b. What precautions can be taken to guard against these risks?
- c. If any of the preferred sites were to be severely damaged, how would this affect the routine immunization programme and a post disaster emergency response?

4. Compare the suitability of possible sites:

Consider the following issues before a site is finally selected:

Access

- a. Is the site close to the relevant transport links, including roads and airport?
- b. Is the site well served by public transport? Public transport is needed by store staff. It may also be required by health workers when collecting vaccine.
- c. Is the site conveniently located for permanent and supervisory staff?
- d. Is the route to the site accessible throughout the year?
- e. Is there adequate access and parking space for vehicles?

Services

- a. Does the site have a reliable mains electricity supply?
- b. Is there a stand by generator?
- c. Does the site have a reliable telephone service?

Security

- a. Would the site be secure?
- b. Could the store be properly monitored and supervised outside normal working hours?

Site development

- a. Is the site well drained and without any risk of flooding?
- b. Are ground conditions suitable for building economically?
- c. Could the site be developed at an acceptable cost?

Notes

.....

.....

.....

.....

.....

.....

.....

.....

.....

.....

.....



2. Building standards

Vaccine stores should be housed in permanent buildings, which should be designed and constructed to a good standard that is appropriate for local climatic conditions. Temporary buildings should be avoided since it is difficult to relocate WIC/WIF. They are rarely satisfactory and are expensive to maintain.

If the store is in an area affected by flooding it should be on high ground or raised above flood level. The loss of a major vaccine store in a natural disaster has potentially life threatening consequences for the population concerned. If an existing building is used it must be in good condition. If necessary it should be repaired and upgraded first.



The following minimum standards are desirable in any vaccine storage building. Most are essential in a primary or intermediate store.

Roof and ceilings

Roof and ceiling of the cold rooms should be in good condition, completely free from leaks.

Roof space should be insulated and/or ventilated in hot climate areas and insulated in cold climate areas.

Ceiling should be in good condition and freshly painted. The ceiling should completely seal off the roof space in order to protect against dust and pests.

Walls and columns

Should be in good condition, free of cracks and other structural defects. Free from rising or penetrating damp, termites.

Insulation in cold climates

Insulations should be nicely finished internally and externally to a good standard. The internal finishes should be dust free.

Windows, screens and doors

Windows should be in good condition, with no broken glass, and should have secure locks or catches. All window openings should be fitted with security grilles. All external doors and all internal doors to rooms containing valuable items should be fitted with security locks.

Notes

.....

.....

.....

.....

.....

.....

.....

.....

.....

.....

.....

Floors

Flooring should be smooth, level and completely free from rising damp, suitably finished with floor paint, tiles, terrazzo, vinyl sheet or some other washable material having dust free surface. Floors on which cold stores are to be built must be levelled to a tolerance of ± 3 mm over the area of the cold store. It is desirable for cold stores to be raised on a low plinth (75-100 mm).

This prevents water used for floor washing from running under the floor panels. Alternatively, the junction between the cold store and the floor may be sealed with waterproof mastic.

Fire protection

The building should be easily accessible to the fire service. A water hydrant should be provided if this is required by the fire service.

The building should not contain a kitchen or other significant fire hazard. The building should be of non-combustible construction or should be lined with non combustible sheet materials.

Rooms used for storing packing materials and other combustible items should be isolated from the vaccine store by fire resisting construction and by fire resisting self closing doors.

Flammable rubbish, such as cartons and boxes, must not be allowed to accumulate in the store.

Smoking should be forbidden and "No Smoking" signs should be displayed throughout the store.

The building should be fitted with fire and smoke detectors connected to an external alarm sounder.

There should be at least one carbon dioxide or ABC type fire extinguisher close to the entrance door for extinguishing electrical fires.

In addition there should be at least two carbon dioxide, powder or water extinguishers within 30 metres of any part of the vaccine store for extinguishing other types of fire.

Fire detection and fire fighting equipment must be inspected regularly, and staff must receive adequate training in fire fighting techniques and emergency action. There should be regular fire drills. Emergency alarm should be there.

Notes

.....

.....

.....

.....

.....

.....

Electrical services

All power and lighting circuits must be in a safe condition, tested and approved to national standards by a qualified engineer or electrician.

Power circuits serving refrigeration equipment must be rated to suit the required refrigeration starting and running loads with proper earthing.

Ancillary electrical equipment (fans, air conditioners, light fittings, etc.) should have no significant electrical or mechanical defects.

Heating and water supply systems

All pipe work should be in good condition, free of leaks.

Heating systems should be fully operational and controllable.

Drainage

Drainage systems should be fully operational and free of blockages.

The surface water drainage system to the building and site must be effective even at the height of the rainy season.

Pest control

The building should be designed and maintained so as to minimize infestation by insects, termites, rodents, bats or other pests.

Cleaning

The building should be cleaned two or three times a week and adequate equipment should be available for this purpose.

Security

The building should be secured against break-ins and should be located so that access to it is controlled.

Notes



3. Vaccine Safety

The primary task when looking after a cold room or freezer room is to protect the vaccines from damage. All vaccines are virtually damaged if they are exposed to excessively high temperatures. On the other hand, some vaccines are quickly destroyed if they are frozen. Damaged vaccines lose their potency and children who are immunized with such vaccines are not protected against those diseases.

Know correct storage temperature of each vaccine.

Learn the correct storage temperature for each vaccine. Keep a storage temperature checklist in the vaccine store so that you can check if you are in doubt.



Temperature sensitivity of vaccines

WHO recommends the range of temperatures for storing and transporting vaccine on the basis of data supplied by manufacturers.

Each vaccine has its own specific storage requirements so it is extremely important to know how long, and at what temperature, each vaccine can be stored. All vaccines can be stored at positive temperatures (between +2 °C and +8 °C). However, only some vaccines can be stored at negative temperatures (between -15 °C and -25 °C).

Loss of potency due to heat

Vaccines that have been exposed to temperatures above +8 °C may lose their potency over time. The vaccine vial monitor (VVM) must always be used to guide decisions on the use of vaccine.



Heat
(Temp above +8°C) -
all vaccines under UIP

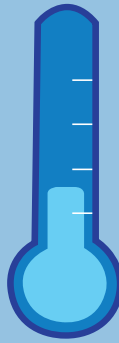

Cold
(Temperature below +2°C)
- Hep. B, Pentavalent,
IPV, DPT and TT



Light
BCG and
Measles/MR

Figure 5: WHO norms for storing vaccine

	Primary	Intermediate		Health Centre	Health post
		State	Districts		
OPV	-15°C to -25°C			+2°C to +8°C	
RVV					
BCG	WHO no longer recommends that freeze-dried vaccines be stored at -20°C. Storing them at -20° C is not harmful but is unnecessary. Instead, these vaccines should be kept in refrigeration and transported at +2°C to +8°C Rota & Pentavalent vaccine temperature and sensitivity				
MR/Measles					
Pentavalent Vaccine					
HepB					
IPV					
DTP					
TT					
PCV					
Diluent vials must NEVER be frozen. If the manufacturer supplies a freeze-dried vaccine packed with its Diluent, ALWAYS store the product at between +2°C to +8°C. If space permits, diluents, supplied separately from vaccine may safely be stored in the cold chain between +2°C to +8°C					

Notes

Freezing

The “T series” of vaccines (DPT, TT), Hep B, liquid Hib and liquid pentavalent vaccine should always be stored between +2 °C and +8 °C as they are damaged by freezing; they may also be damaged by exposure to freezing temperatures. Hep B is the vaccine most sensitive to freezing temperatures. The most common cause of exposure to freezing temperatures is the failure to correctly condition ice packs prior to transport. To reduce the overall risk of freeze damage to vaccines, one should follow the best practices for prevention of freeze damage to vaccines (WHO/IVB/07.09). If it is suspected that vaccines have been exposed to freezing temperatures, perform the “shake test” before deciding whether the vaccine is damaged or not. The VVM does not indicate if a vaccine has been frozen.

Notes

.....

.....

.....

.....

.....

.....

.....

.....

.....

.....

.....

.....

.....

.....

.....

.....

.....

.....

.....



WIC/WIF & its Components



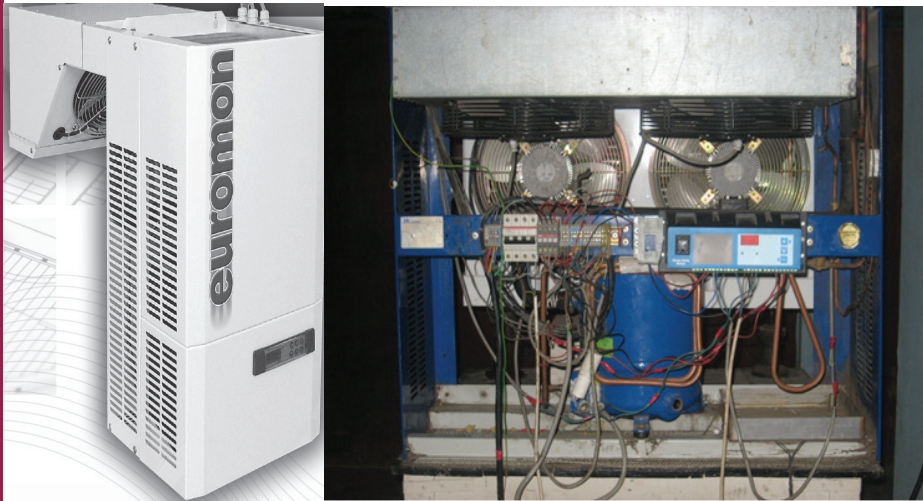

Learning Objectives

A brief about Walk-in Cooler (WIC)/Walk-in-Freezer(WIF)

Components for WIC/WIF

Accessories/Miscellaneous Components.

Interfacing Equipments





Walk-in-Cooler(WIC)/Walk-in-Freezer (WIF)

WIC /WIF is a complex engineering structure, and trained workers, both for the vaccine storage and for the technical maintenance must operate it.

Walk in Cooler (WIC) are used for storage of very large quantities of vaccine between $+2^{\circ}\text{C}$ to $+8^{\circ}\text{C}$.

Walk in Freezer (WIF) maintains temperatures between -15°C to -25°C used for storage of OPV, measles and mumps vaccines and frozen icepacks and, if necessary, freezing of icepacks.

The main operational points are the same as those for a Walk in Cooler, however, remember to use gloves and a freezer coat when working inside the freezer room.

WIC/WIF rooms are a key point in the cold chain. Proper management has positive impact on both the quality of the stored vaccine and on the environment in terms of energy savings. This insulated room is kept cold by two nos. of cooling /freezing units, mounted on its walls (In case of mono block).The working of the

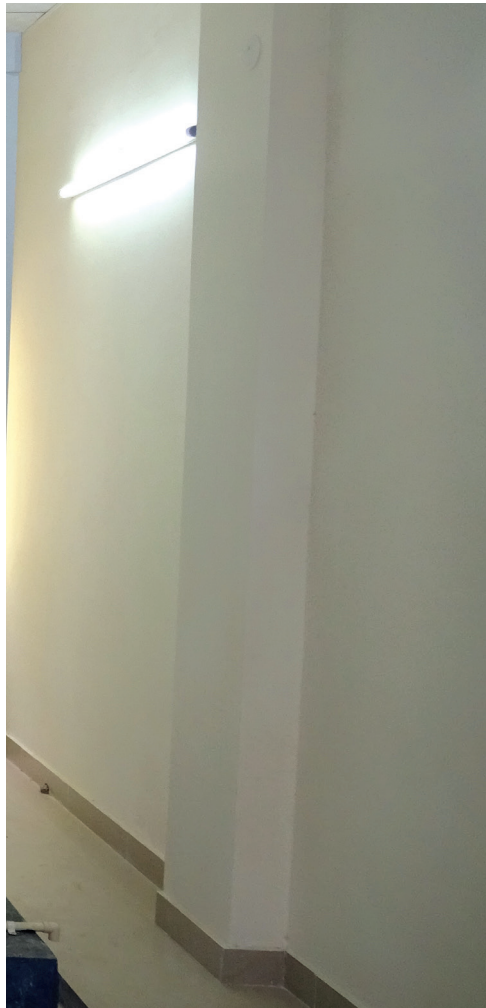

refrigeration units are controlled by their thermostat to maintain the inside temperature within $+2^{\circ}\text{C}$ to $+8^{\circ}\text{C}$ in case of Walk-in-Cold Rooms and -15°C to -25°C in case of Walk-in-Freezer Rooms. One Cooling / Freezing unit is sufficient to maintain the temperature in the required range. The second unit is provided as standby.

The condenser fans of the units (outside the cold /freezer room) cool the condenser coils and they run only when the compressor is running and sufficient pressure builds up in the condensers. Defrosting of the evaporator is done automatically by the defrost timer or defrosting signal from digital temperature controller, at preset intervals for predetermined periods. This allows the frost to melt and drain out.

NOTE

Only one unit works at any time. But in the old models of the WICs the thermostats of the units are so adjusted that one unit works when the inside temperature is about $+5^{\circ}\text{C}$ and goes off at about $+4^{\circ}\text{C}$ and the other works when the temperature is about $+7^{\circ}\text{C}$ and goes off at about $+6^{\circ}\text{C}$. Therefore, when the temperature is around $+5^{\circ}\text{C}$, only one unit works. But, if due to door opening, storage of new vaccines, higher ambient temperature, and power failure etc. the temperature of the cold room rises above $+7^{\circ}\text{C}$, both the units work together. When the temperature comes down to about $+6^{\circ}\text{C}$ the 2nd unit stops and only the first unit works and maintains the vaccines at the lower temperature. The evaporator's fans of the cooling /freezing units (inside the cold/freezer room) blow the cold air from the evaporator and circulate it inside the room. They run continuously.



The desired features in Cold/Freezer room are

- Polyurethane foam should be of State-of-the-art as; high pressure polyurethane foam machine ensures the maximum insulation values possible for the prefabricated sandwich panel.
- There should be consistent density with thermal conductivity less than 0.024W/mK.
- Manufacturing standards should be such that, PUF panel should have a smooth and even surface. Manufacturing methods with constant temperature and pressure setting further enhances foaming quality.
- Polyurethane panel's uniform density is over 40kg/m³, which provides structural rigidity and dimensional stability.
- Fire retardant should be added into polyurethane insulation panel, in such a way, which allows self-extinguishing time less than 3 seconds, providing a safer environment.
- Joining mechanism for PUF panels should be with Cam action- so that tongue and groove edges offers ease and flexibility of a strong unit construction.
- A dual gasket system for sealing security to avoid cool air leakage from the cold storage room.
- In fitting door panel is equipped with self-closing hinge to reduce unnecessary loss of refrigerated air from the walk in cooler & walk-in freezer.

Especially in case of WIF.....

- The concealed heater wire circuit inside the door frame should be there to prevent condensation and frost formation at the edges of door and frame.
- Pressure relief port eliminates the damage to the vacuum compartment as a result of pressure differences between the interior and exterior spaces of the refrigerated room.

Characteristics of walk in cold/freezer rooms

Size of walk in cold rooms	Grossvolumeofcold rooms	Grossing factor	Netstoragecapacity (litres)
WICR-5m ³	5	3.2	1,563 liter
WICR-10m ³	10	3.3	3,030 liter
WICR-15m ³	15	3.7	4,054 liter
WICR-20m ³	20	3.9	5,128 liter
WICR-30m ³	30	4.2	7,143 liter
WICR-40m ³	40	4.2	9,524 liter
WICR-60m ³	60	4.05	14,815 liter
WICR-80m ³	80	4.2	19,048 liter
WICR-90m ³	90	4.1	21,951 liter
WICR-120m ³	120	4.2	28,571 liter
WICR-160m ³	160	4.2	38,095 liter

NOTE

Walk-in coolers and freezers of different temperature classifications are equipped with different insulations and compressor types, therefore high temperature walk-in -cooler cannot be used as lower temperature walk-in freezer. Besides, low temperature walk-in freezer room is not recommended to be used as higher temperature walk-in cooler room, because walk-in cooler operates most efficiently at designed conditions. Walk-in cooler / freezer refrigeration system are constructed with different materials. As a result they should not replace each other in application.

Walk-in cooler / freezer refrigeration system operates with the highest efficiency when working amount is in accordance with design capacity.

Components for WIC/WIF

I) Cold room panels (Prefabricated PUF panels)

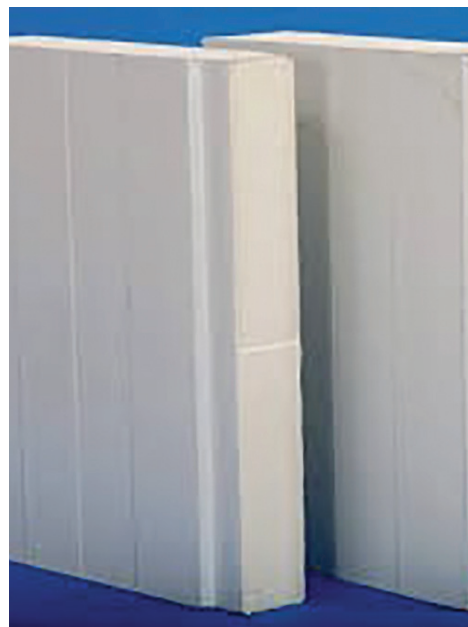

Polyurethane Foam (PUF) Panels available are of various thicknesses and lengths. With its use, the walk-in -cooler/Freezer can be assembled into different height, width, length and types all with ease of assembly. Polyurethane is an ideal insulation with low coefficient of heat transfer and high density. Available finishes are galvanized steel, stainless steel, embossed aluminum, galvanized steel with optional colours.

Most commonly used dimensions are:

Up to 3m: 60mm, 80mm, 100mm, 120mm

Up to 5m: 60mm, 80mm, 100mm, 120mm

Up to 7m: 60mm, 80mm, 100mm, 120mm

While selecting the PUF panel following factors were taken into account.

- Energy Saving
- Mechanical Strength
- Better profitability
- Fast deployment
- Long Life
- Maintenance Free
- Fewer loads on refrigeration unit
- Aesthetic look
- Easy housekeeping
- Overall Heat Transmission Coefficient
- Insulation Section of cold storage design
- Thermal Conductivity (K) of the material decides the insulation property of the material. Lower the K value, better the insulation property.

K value of some of the insulation materials are given below:

Mineral Wool:	0.028W/mK	[Open Cell]
EPS (Expanded Polystyrene):	0.036W/mK	[Open Cell]
PUF (Polyurethane Foam):	0.023W/mK	[Close Cell]

PUF is better insulating material than rest of the two. More over it is close cell. The open cell allows moisture ingress and deposition causing poor insulation. Since K value (Thermal conductivity) for PUF is lower than rest, so for the same insulation effect, the thickness required by PUF will be lesser than rest two, means more space in cold storage.

Major advantage of better insulation is energy saving as well as lesser cost on maintenance of refrigeration compressors.

The desirable features of PUF insulated panel are

- High thermal efficiency which ensures low heat transfer means low refrigeration load. As Major cost for any cold chain operation is electricity, Lower the refrigeration load, lower the electricity consumption, which ultimately results Low operational cost.
- High mechanical strength, for making it possible to go for larger spans as well as large partition walls. This is helpful in giving aesthetic appearance.
- Panel's joints should be preferably with CAMLOCK and also additionally joint with tongue and groove configuration.
- Erection or dismantling of the panels should be easy
- Thermal efficiency of panel should not deteriorate over a period of time, for making it long lasting insulation solution

II) Refrigeration Units

Two distinct types of Refrigeration Units exist in the cold chain market -

- Mono block
- Split-Type

Mono Block Refrigeration Units (Plug-n-play model)



This is an easy to install system which has all the controls, the compressor, condenser and evaporator as a complete unit, assembled and ready for installation. Each WIC/WIF room is supplied with two complete plug-n-play refrigeration units to provide 100 per cent stand-by cooling. These are hung on the prefabricated panel walls of the WIC/WIF, or mounted on the ceiling panels. Monoblock refrigeration units designed for large cold room refrigeration at medium, high and low temperature, as well as high humidity applications. The Mono block unit on a cold or freezer room is the entire sealed refrigeration system for the cold room to include the internal fans and the outside control panel. Using a template to fit an integral system you would cut two small slots in the cold room panel and sit the refrigeration system over the panel like a saddle.

Very reliable and cost effective option as specialist refrigeration engineers are not required to carry out the installation. The Mono block units are factory set ready for operation. Mono block refrigeration systems are also referred to as Integral refrigeration systems or straddle systems.

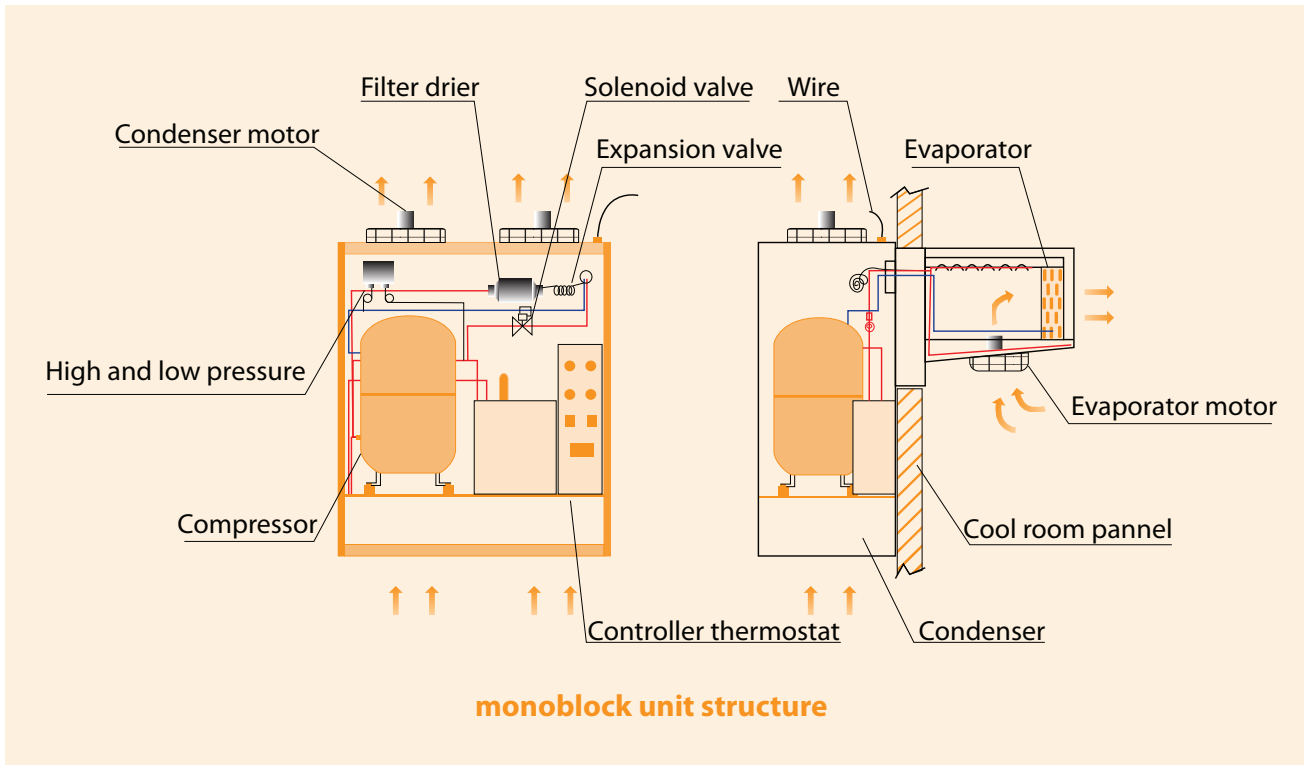

Notes

A series of horizontal dashed lines for taking notes.

Advantages:-

The genuine technical advantages offered by mono block generation is

- Fast, easy and safe installation.
- The mono block unit may be easily wall mounted in the cold storage room. At least two fastening points have been incorporated on the compressor side to fasten the mono block unit outside the cold room. It is easy to be installed, with compact overall dimensions.
- As with, compact framework, reduced the installation space, the installation method for this unit is extremely simple. Simply slot the mono block unit into the notches in the top panel of the cold room and secure it.
- Products assembled, tested and factory-preset according to the application. Once in place, the unit is ready for use as soon as it is plugged into an electrical power point.
- Mono block unit designed for use in small cold rooms from 5 to 50 m³.
- Mounted across the cold room panel; extremely compact unit cooler for optimum use of space in the cold room.
- Furthermore, the various control parameters are all factory-preset according to the application.
- Maintenance costs are comparatively low.
- It can be widely applied in miniature/medium sized cold room.
- With Hermetic compressor, high reliability with high efficiency
- Low noise level.
- The front cover is designed in two parts rendering easier access to condensing unit components, in particular the compressor, condenser fans and re-evaporation heater. (Total accessibility)
- The controller is equipped with a plug-in terminal rail for easy maintenance.

Disadvantages

- The main disadvantage of plug-in models is the refrigeration units generate hot air in the vicinity of the cold room which affects the efficiency of the refrigeration system if sufficient ventilation is not provided.
- Mono block type refrigeration systems can be possible heat and noise level generating units.
- In humid countries this could also cause formation of condensate in WICs with the potential for vaccine wastage through peeling of labels on vaccine vials. Isolation of the condenser section is therefore recommended and fitted with ducting and air extract fans to remove the hot air from the room.
- The refrigeration system takes up some space on the cold room wall.
- Not suitable where ambient is reasonably high.

Split Systems

b. Split-type model

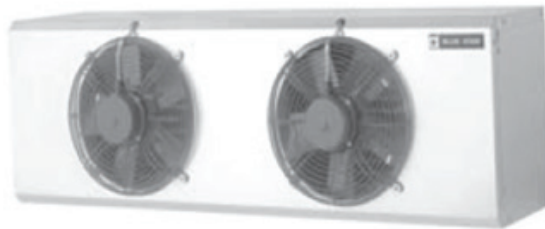

Evaporator Unit



Condenser Unit



Unlike the Plug-n-play refrigeration units, the Split unit refrigeration model consists of two main parts - the condensing component for installation outside the WIC/WIF room and the evaporator component for installation inside the cold room. These two parts of the refrigeration system are not operational on receipt from the supplier. They have to be wired, piping connections made and charged with refrigerant gas after installation. At the site of installation, these parts are linked with solid leak proof connection tubing to the evaporator and the condensing unit. The installation process requires an experienced refrigeration technician to make leak proof connections as well as the electrical wirings. The Split Type Refrigeration Unit is suitable to Indian weather conditions.

Remote refrigeration refers to where the evaporator is located within the refrigerated space but the condensing unit is located elsewhere normally outside of the building or in a suitable plant room. These systems are one-to-one systems consisting of one evaporator (fan coil) unit connected to an external condensing unit. Both the indoor and outdoor units are connected through copper tubing and electrical cabling.

The purpose of this is to discharge the heat removed from the room to the external environment thus avoiding the discharge of heat into the area surrounding the Cold/Freezer room. The indoor part (evaporator) pulls heat out from the surrounding air while the outdoor condensing unit transfers the heat into the environment.

Advantages of using Split Systems

- Low initial cost, less noise and ease of installation;
- Condensing unit can be located where noise generated from the condenser/compressor causes minimal disturbance, and where heat emissions generated by the compressor and condenser units do not affect the ambient temperature of room where the equipment is installed.
- Good alternative to ducted systems;
- Each system is totally independent and has its own control.
- Heat and noise levels are taken away from the cold room area.
- The external unit stays cooler therefore more efficient and less likely to break down.

Disadvantages:

- There is limitation on the distance between the indoor and outdoor unit i.e. refrigerant piping can't exceed the limits stipulated by the manufacturer (usually 100 to 150 ft) otherwise the performance will suffer;
- Maintenance (cleaning/change of filters) is within the occupied space;
- Limited air throws which can lead to possible hot/cold spots; Outdoor units may spoil the appearance of the building if not installed properly.
- The costs involved as specialist engineers are required to carry out the installation. Repair and service costs are higher on remote systems.

Notes

Available Features

Both Mono block & split type refrigeration units can be provided with Automatic & intellectualized Electric control, with the function of temperature setup/control & electric defrosting.

The units can be provided with a protection of over loading, sub-heating, pressure etc.

Digital Temperature Controller for Cold/Freezer room operations

The controller controls complete operation of compressor/condenser fans/ evaporator fans & defrost mechanism. The defrost in the system based on either an electrical heater where the compressor is stopped, or at cycle inversion using warm gas where the compressor keeps on working. There are safety features which include shutting down the system in case of a fault.

A series of "safety controls" (delay at start-up, minimum disable time, minimum time between activation) protects the compressors from close starts. In case of probe error or temperature alarm, the instrument signals the event through acoustic signal and by closing the relay contact. By pressing the mute key, the buzzer is silenced.

A number of parameters are displayed alphanumerically to set up the instrument for each specific function. PC Connectivity and Remote monitoring (Optional).

Common controllers in use are:

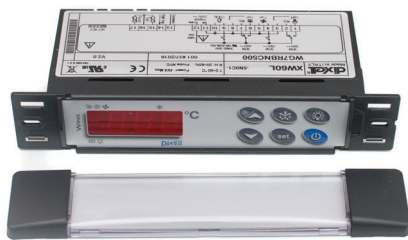

Notes

Notes section with horizontal dashed lines for writing.

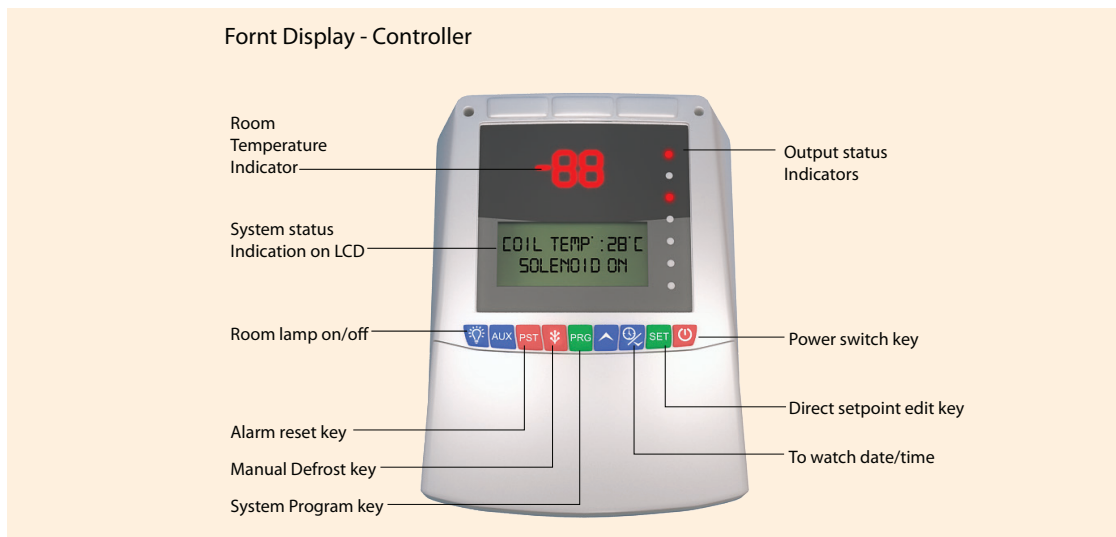

The main devices that normally need to be managed by an electronic controller are:

Probes for measuring room and defrost temperature (if featured)

- Compressor
- Defrost heaters/Solenoid valve for Hot Gas Defrosting¹
- Evaporator fans
- Lights
- Door switch
- Alarms
- Condenser fans

Control Parameters categorised are,

- Regulation
- Display
- Alarm
- Analogue Inputs
- Defrost
- Fans
- Miscellaneous
- Digital Inputs

1(See Annexure I)

III) Cold/freezer room control panel



The cooling /freezing units for WIC & WIF require single/three phase, 50 Hz, AC power supply for its operation. The panel which is being used to supply this power is known as Cold/Freezer Room panel.

The Cold / Freezer Room panel also supplies single phase power to room lights, Door Heater, Alarm system adapter and also to the Pressure Relief Valve heater in case of WIF. The Cold / Freezer Room panel receives 1/3 phase A.C. power from Generator Control panel/AMF panel. The Generator Control panel/AMF panel in turn receives power either from the mains (Network) or from Generator. (In case of mains failure.).

Accessories/Miscellaneous Components.

Monitoring of cold room temperature ensures that the vaccine has been kept in safe and secured conditions. Many variety of temperature monitoring devices are available in the market with advance technology that allow remote monitoring of WIC/WIF. Temperature monitoring devices, especially the mechanical devices require regular maintenance.

WHO recommends monitoring of the temperature of all cold chain equipment including WIC/WIF at least twice a day. It is critical to ensure that the quality (potency) of vaccine is maintained at national and regional stores by stocking the vaccines at recommended temperatures. It is very critical, therefore, to monitor the temperatures of WIC/WIF round the clock.

Temperature monitoring is regular and continuous process. There are several ways of monitoring the temperature. A brief information about the temperature monitoring/recording devices, most common in use at national/state/regional vaccine stores, are given below.

Temperature Recorder

Cold room temperature recorder are a component of WIC/WIF which takes and plots the temperature readings every one hour on a circular 7 day temperature chart.

The chart should be replaced every week. The weekly chart should be marked clearly with starting and ending date, reference of WIC/WIF and name of the store.

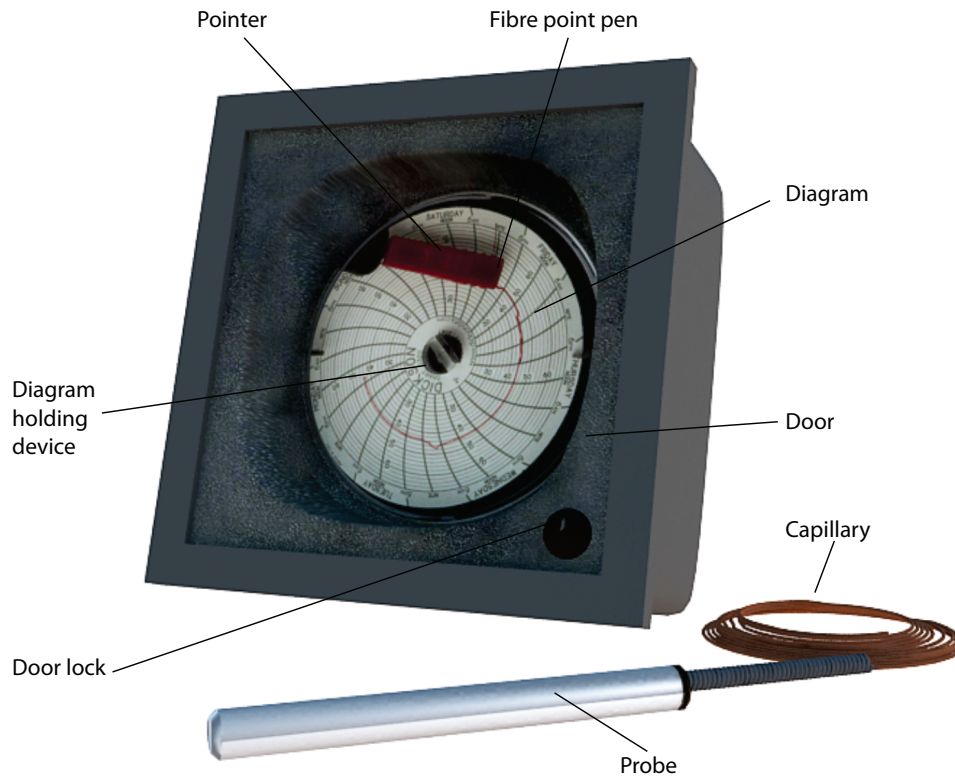

- The temperature recorder records the cold room temperature continuously on a circular chart. Normally the record is set to turn the chart on complete round for 7 days and the chart has to be changed weekly. The fiber pen which is marking the temperature on this graph should be replaced when the ink exhaust. The Temperature recorder runs from a 1.5 Volt dry-battery source (Torch cell) and hence no external supply is necessary.
- Install it at a suitable location. The sensor cable may be taken to inside, making a suitable hole on the wall.

The following performance specifications should be met:

- Upper and lower limits + 50°C to - 30°C.
- Accuracy +/- 1°C.
- Resolution +/- 0.5°C.
- Refillable or inkless pen.
- Minimum acceptable recording period between chart changes is 7 days.
- Power source 110/240 volts 60/50 Hz mains operated with rechargeable and replaceable battery backup with 48hrs charge capacity (PQS E06/TR04).

Dial thermometer (optional):

A vapor or gas pressure dial thermometer for ease and quick reference of temperature to be mounted on the front face of the WIC/WIF in line with WHO/PQS/E06/TH01.1 performance specifications. This is intended for visual temperature monitoring/checking where electronic data temperature data logger could be installed at a secluded and not readily accessible location.



Computerized temperature recorders

The best way to monitor the WIC/WIF temperature is through computerized temperature monitoring system. This kind of monitoring will lead to real time temperature monitoring for 24 hrs. It gives automatic report generation (daily, weekly and monthly & date wise), automatic alert on landline, mobile phones, Fax, emails and alarms/hooters.

A. Wired Temperature Monitoring Data Logger system.

These type of data logger has been designed to perform two major tasks. It records the temperature from installed and connected sensors at a defined frequency. The data logger is triggered ON to start recording through the computer software. The data logging however does not require the computer intervention. The computer is required to trigger the data logger to start recording and to download the recorded temperature readings. The computer intervention is also required to reset the data logger to clear the memory. The second function of these data logger is to raise alarms in case of temperature violation. The data logging process is as follows in general



The data logger is programmed to record the temperature from 16/20 sensors at the preset frequency intervals. The data logger has the capacity of recording/storing 2000/3000 temperature readings. The frequency of temperature recording is pre defined.(From sec-several min).When needed, data could be downloaded to computer and data logger is reset to record fresh readings.

The data logger should have the following main features:

- Temperature sensor for specific locations within the cold room.
- Door open sensor for detecting whether door is open or closed.
- Logger unit for recording data received from the individual sensors.
- PC to store, display and print temperature and event records (or recommended PC model which is compatible to the data logger including any software required).

- Alarm sounder triggered whenever sensor records a temperature or event excursion outside programmed norms.
- Auto dialer which dials pre programmed telephone numbers.
- System software designed to drive all system elements described above.

B. Wireless Temperature Monitoring Data Logger system

Wireless temperature monitoring data logger system has been especially designed to monitor the temperature of cold rooms and freezer rooms.

The sensors are placed at ideal location inside the WIC/WIF which is connected by wire to the radio module installed outside the cold room. Generally each module is capable of accommodating 8 sensors. Radio module transmits the real time data through radio frequency to radio receiver. Radio receiver is connected to computer where the data is interpreted.

This system is capable of recording temperature at user defined frequency which can range from every 1 minute to every 1 hour. The ideal frequency of recording the temperature is every 1 hour.

Radio modules and radio receiver works with electrical power supply with a standby battery backup. The standby battery should be checked on periodic basis. This may need replacement every 6 months. The system is capable of generating periodic reports such as, daily, weekly and monthly temperature line charts.

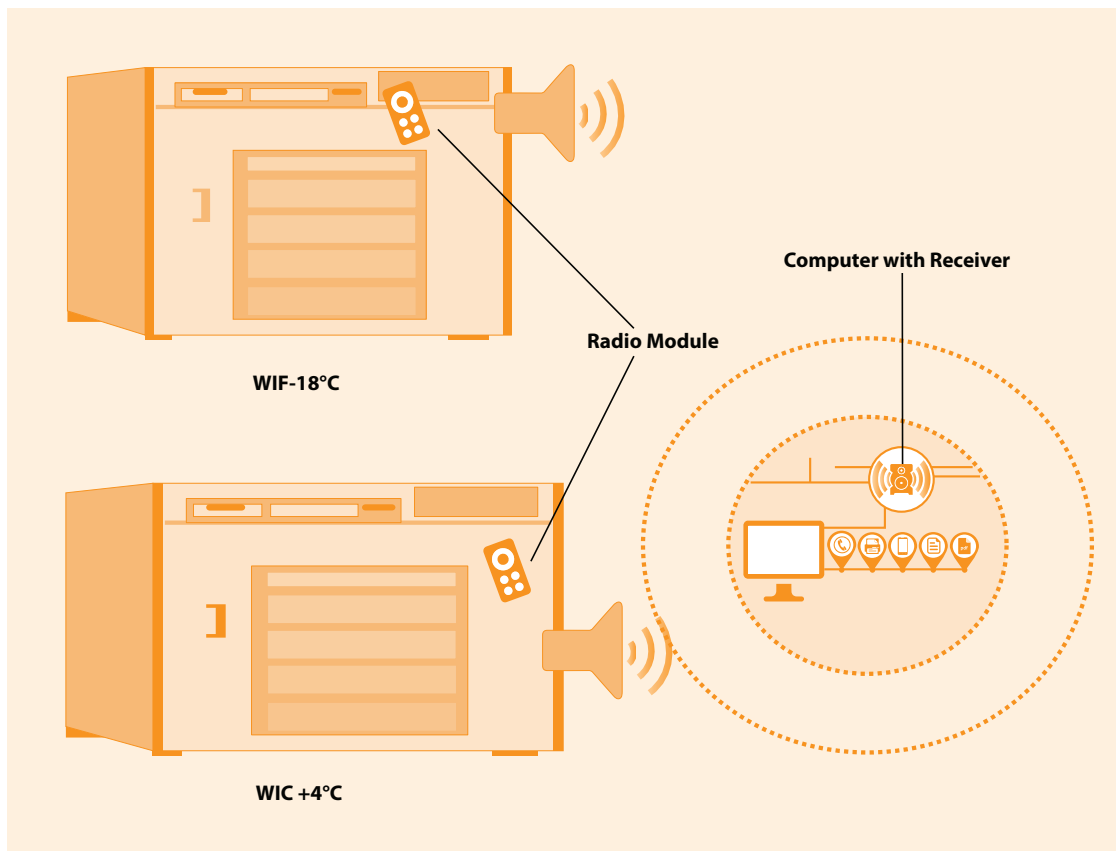

Operating System of Wire Less Data Loggers

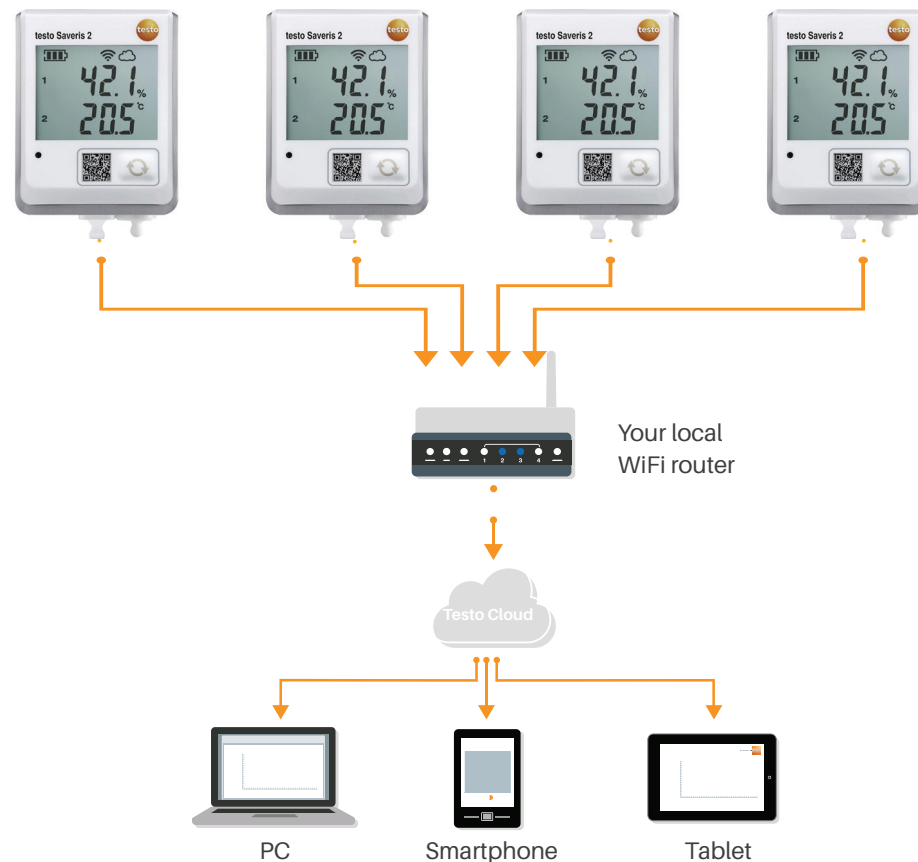

For Temperature mapping exercise please refer Annexure II

For better & precise temperature monitoring/recording the functional requirement for Wireless Temperature Monitoring Data Logger System are as under:

- Mapping and monitoring at device level using a LCD display, and having LED indicators/ hooters that will help local action immediately.
- To reduce cost of operation, unit need to on electricity using appropriate adapter and has battery back-up. Battery needs to be rechargeable in nature and preferably Li-Ion or Li-Polymer type for better performance.
- There should be more than one, preferably minimum 4-sensors (with accuracy of +/- 0.5°C or better) to be connected to each device fitted on WIC-WIF for effective temperature mapping.
- Each unit to have a display (+/- XX.X°C), indicating temperature of selected sensor or all sensors sequentially. This feature needs to be user configurable.
- Each unit should have provision for installing humidity sensor (Optional, +/- 2%), if required.
- Device with memory to ensure data storage. This data needs to be stored and sent to the server whenever internet connectivity is available. If using GSM based for communication, dual SIM to be provided in order to ensure reliable connectivity for alerts, in case of network problem/ low signal strength. This will help to have better redundancy in the communication.

- No wired communication between WIC-WIF. Communication should be Wireless, using GSM technology. (Similar to WiFi router network).
- Short range WiFi devices also can be considered at GMSDs/ State Vaccine Stores level.
- To address the issue of long distance communication between WIC-WIF, repeaters with reliable connectivity with PC or internet to be provided. Device used for internet data transmission must have security protocols, to prevent hacking/ data theft.
- Web-based monitoring of temperature data preferably with a time-temperature graph, for all sensors' data on same chart for one device.
- Provision for calibration of temperature to be provided for each sensor.
- Data should be property of the client and not to be a third party venture, and should be with client server (if required).
- It should be possible to configure the device only through authorised access by using Web-Interface and not locally to prevent change in data/ settings. No provision should be available to tamper/alter already recorded temperature data.

VI) Temperature Monitoring Alarm System:



An Alarm system is provided to monitor the cold /freezer room temperature. It actuates Audio and Visual alarm immediately, in case of the temperature goes down & crosses the lower setting. But when the temperature rises to the upper set limit, it operates with a preset delay. In alarm condition, pressing a button can stop the Audio alarm, but Visual alarm will continue till the alarm condition prevails or the alarm system is switched off. There is also a test button provided to test the functioning of the alarm system.

Alarms (standard):

Alarms should be mains operated and audible with battery back-up with automatic recharge and triggered in the event of mains failure or when cold/freezer room temperatures are outside set limits

Alarms (optional):

Audible alarms forming a part of programmable electronic temperature and event logger system with an auto dialler to specific personnel responsible for the cold chain store.

Interfacing Equipments

As mentioned earlier WIC/WIF is a Turnkey solution & many interfacing equipments are involved for assisting WIC/WIF to give the trouble free operation. A brief information about the same is given as below.

I) Servo Controlled Voltage stabilizers

Voltage stabilisation & surge protection will be generally required for cold room & freezer room installation. At most of the places supply systems considerable variation is encountered in the mains voltage for which it is designed. The hazards of over-voltage are well known and these voltage fluctuations constitute a serious problem for WICs and WIFs as it have electronic components and controls systems which are susceptible to power fluctuations. Intermittent national grid power supply during start-up on heavy load pick-up and shut down, results into transients that also contribute to system failure. This creates high surges that are detrimental to sensitive components and accessories, leading to their failure and consequently that of the WICs/WIFs. It is therefore recommended to have the power supply for WIC and WIF rooms with stabilisers which only allow power to the system when pre-set conditions are met.



Servo type Automatic Voltage Stabilizers are based on the principle of feedback information, These regulators are high speed electromechanical regulators and are available with latest technology so as to provide constant voltage for supplying the desired voltage without any harmonics and can even operate over a wide temperature range.

The Servo Stabilizers uses an advanced electronic servo-motor concept to control a motorized variable transformer. Because of the motorization, there is a small delay in voltage correction. However, output voltage accuracy is usually $\pm 1\%$ with input voltage changes up to $\pm 50\%$. These machines are not affected unduly by power factor or frequency variation. This type of technology tends to be extremely effective when considering large three phase applications, as it is able to maintain its accuracy of all three phases, both line to line and line to neutral, irrespective of input voltage balance and load balance at any power factor. They are also able to withstand large inrush currents, normally experienced with inductive loads. However due to the mechanics of this type of stabilizer, periodic maintenance is required.

The desired Key Features required for Servo Controlled Voltage Stabilizer are

- High response, low inertia rugged A. C. servo motor.
- Critically damped response on all loads/supply conditions.
- Energy savings due to high efficiency and superior transformer design.
- Use of high quality raw materials used – prime grade CRGO lamination and high purity electrolytic copper wires/strips.
- No wave form distortion.
- High speeds of correction up to 35V/sec for three phase and 20V/sec for single phase.
- Machine wound variacs with special carbon brushes for enhanced life.
- Voltage adjustment on output.
- Simple, systematic construction for dependability and ease of maintenance.
- Solid state control circuitry.
- Conforms to required IS specification.(IS:9815)

II) Diesel Generator Set (DG Set)...



For DG set, diverse cold chain store loads will require appropriate sizing to match the equipment installed. This should take into account refrigerators and freezers installed in the cold chain store. The preferred option is that DG set should supply as a part of the cold room/freezer room installation package.

This will be already installed or supplied by others. The design of each specific installation must be coordinated with the standby generator installer.

Cold Room & Freezer room should be provided with continuous quality power supply & are generally connected to a standby generator. Generator packages are designed to provide emergency power during a mains supply failure. The KVA rating of the alternator and panel depends upon the power required to run the cooling units and how many cooling units are connected/functioning at a given time in the vaccine store. Also adequate provision of fuel supply, repair and maintenance should be made available on time, to keep the WIC/WIF units running in the event of mains power failure.

DG Set as a System

Diesel engine is the prime mover, which drives an alternator to produce electrical energy. In the diesel engine, air is drawn into the cylinder and is compressed to a high ratio (14:1 to 25:1). During this compression, the air is heated to a temperature of 700–900°C. A metered quantity of diesel fuel is then injected into the cylinder, which ignites spontaneously because of the high temperature. Hence, the diesel engine is also known as compression ignition (CI) engine.

DG set can be classified according to cycle type as: two stroke and four stroke. However, the bulk of IC engines use the four stroke cycle.

A diesel generating set should be considered as a system since its successful operation depends on the well-matched performance of the components, namely:

- a. The diesel engine and its accessories.
- b. The AC Generator.
- c. The control systems and switchgear.
- d. The foundation and power house civil works.
- e. The connected load with its own components like heating, motor drives, lighting etc.

It is necessary to select the components with highest efficiency and operate them at their optimum efficiency levels to conserve energy in this system.

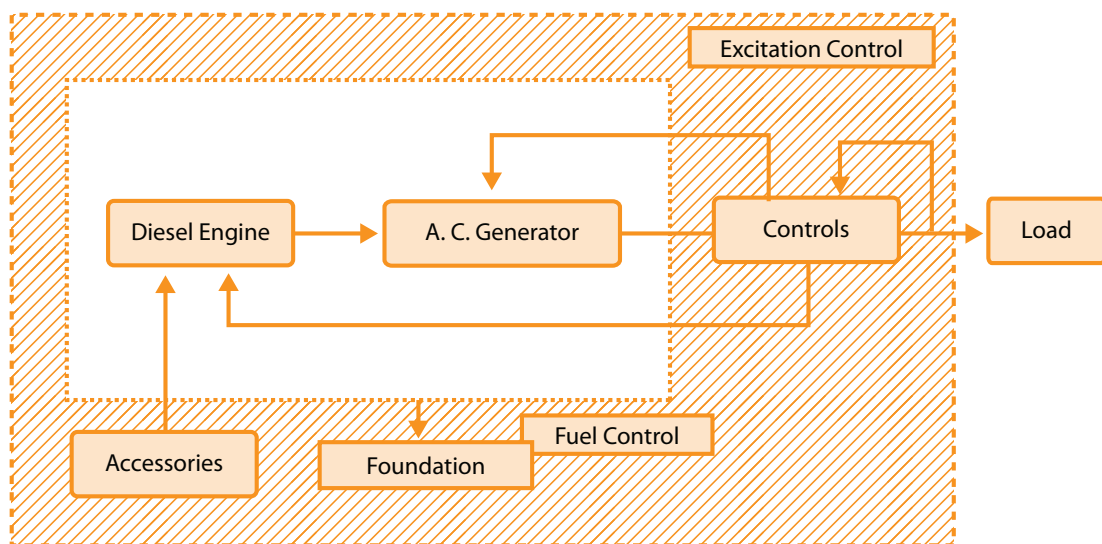

Safety Features

It is advisable to have short circuit, over load and earth fault protection on all the DG sets. However, in case of smaller capacity DG sets, this may become uneconomical. Hence, it is strongly recommended to install a circuit protection.

Other safety equipment like high temperature, low lube oil pressure cut-outs should be provided, so that in the event of any of these abnormalities, the engine would stop and prevent damage.

Neutral Earthing

The electricity rules clearly specify that two independent earths to the body and neutral should be provided to give adequate protection to the equipment in case of an earth fault, and also to drain away any leakage of potential from the equipment to the earth for safe working.

A. AMF Panel.

AMF panel continuously monitors the mains & in case of its failure, for any of the reason, it gives command to DG set for starts. The power from the generator is connected, with a delay, to the cooling / freezing unit selected. (The cooling/freezing unit & Alarms/TMDs/lights, etc in use at the time of mains failure). The generator continues to supply the load until the mains supply returns. During GENSET run AMF panel also monitors its healthy operation. The generator then automatically disconnects, stops with a delay and the mains is re-connected to the load. Whenever the generator runs, the run hour counter registers the time of running of the generator. The AMF panel reverts to the standby mode ready to respond in the event of another mains failure.

AMF panel generally is of cubical type made of 16 gauge CRCA sheet with hinged type openable covers mounted above base frame at suitable location of DG set and supported on both sides on base frame. All the control panel wiring is arranged in such a way that should be easily accessible and with sufficient working space for making connections of cables etc. A manual bypass switch generally provided on the control panel for total bypass of the AMF system. The changeover from Mains supply to DG set supply is possible in manual mode with AMF relay totally bypassed. However care should be taken for all the safeties / tripping devices of DG Set should remain functional in manual mode. Available sizes on the market are normally in the range 10-1000kVA. With a latest trend in technology, the AMF Control Panel consists of a state of the art microprocessor-based AMF controller for monitoring, indicating and controlling the Mains and Generator for AMF operation.

Some commonly used AMF controllers are



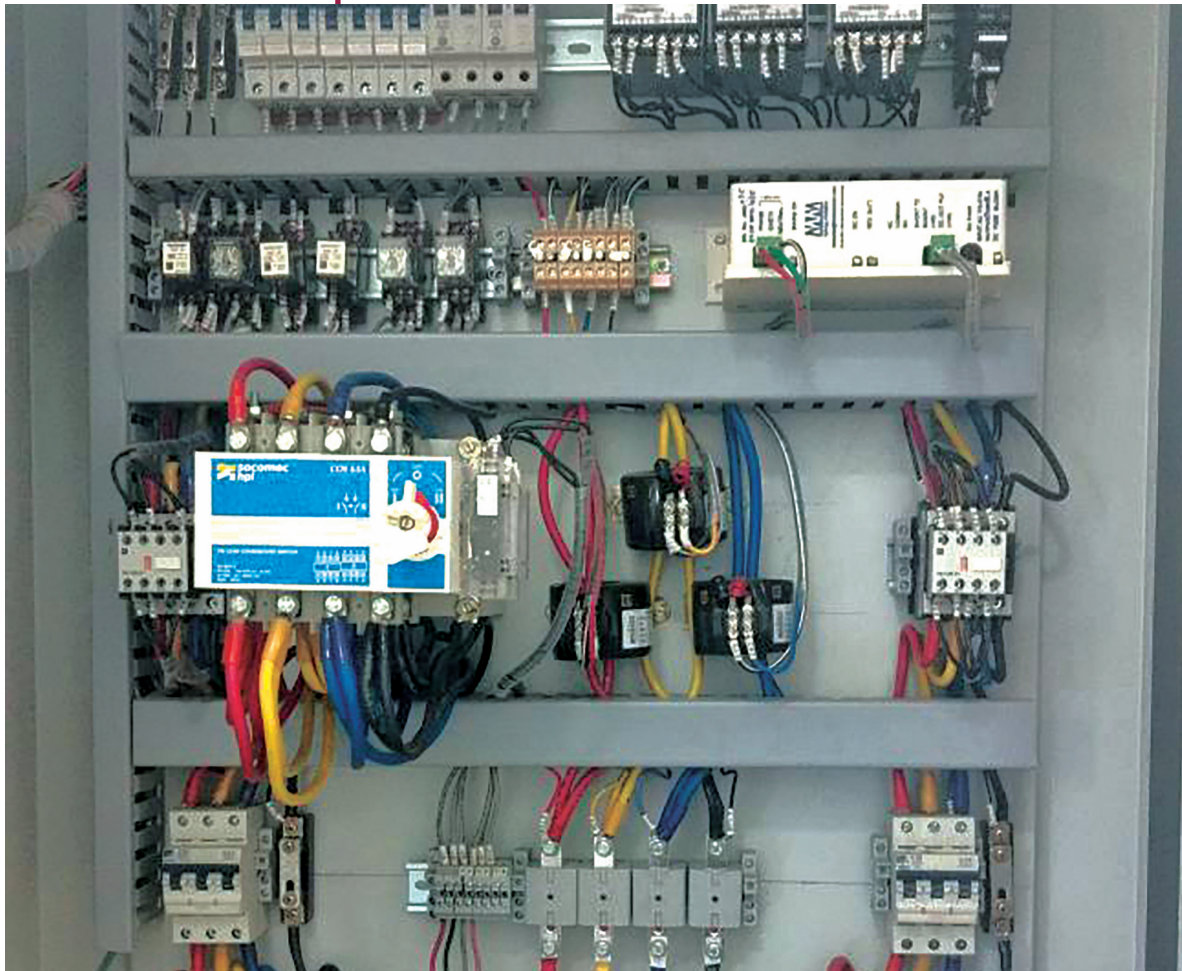

Functional Requirements:-

All the functional requirements in Auto mode are to be achieved through microprocessor based AMF Controller. The logic for starting & stopping shall be:-

- If the mains fail, or one or more phase of mains is not available.
- If any phase voltage of mains is out of preset limits however there should be a provision to set the limits of higher and lower phase voltages as per the site requirement. The mains supply within this range shall be considered as healthy so as to avoid continuous running of Engine Alternator Set.
- The AMF panel system should operate with allowable operating range of mains AC supply & the AMF relay should be able to trigger DG Set for starting and stopping in accordance with this range.
- Switch the load to the engine supply after suitable time delay, after starting the engine on mains failure/phase failure / low voltage / high voltage.
- Switch the load back to the mains supply after suitable time delay, when healthy mains supply is restored and stopping the Engine.
- Attempt to start the Engine up to three times on failure of earlier attempts with suitable time intervals.
- Two level fuel sensors for fuel should be provided at 50% & 25% respectively.

AMF panel system should provide following settable features:-

- Mains failure time - to initiate automatic DG start after 0 to 300 seconds of mains failure.
- Mains restore time - to initiate automatic stop of DG after 0 to 300 seconds of mains in stable conditions.
- Low oil pressure delay time - 0 to 99 seconds delay of the low pressure oil input alarm from engine start.
- Stop solenoid time - 10 to 99 seconds enabling time for "stop solenoid".
- Cranking up time - 0 to 99 seconds enabling time for starter. The timer is reset if the engine starts before the programmed time.
- Start attempts - 1 to 3 numbers of automatic attempts during automatic start cycle.
- Attempts interval - 1 to 99 seconds time interval between starting pulse attempts.
- Cooling down time - 0 to 300 seconds engine cooling time before stopping. During this time the engine runs without load.
- Generator voltage time - time of stable generator voltage to close DG contactor to load (0 to 300 seconds).

New AMF panels is also having facility for RS 232 serial communication interface following TCP / IP Protocol and are compatible for transferring the required data to the monitoring station in excel sheet/pdf formats with necessary software through GSM modem. The responsibility of providing GSM modem along with the required software lies with vendor applying for approval of AMF Control Panel.

As it is an observed fact that GPRS connectivity is not available at all the sites, the connection between the AMF Control panel and monitoring station does have capability for both GPRS & SMS. In such cases, the modem tries 1st for GPRS connectivity and in case of non availability of GPRS connectivity, the SMS should be tried as 1st priority.

For sending alarms and designated events the SMS should invariably be generated from the site only (where the AMF Panel is installed). The communication at the base monitoring station can be either with GSM Modem (with or without server) or with server based internet portal. In either case there should not be any limitation for no. of sites to be linked with the base monitoring station.

Notes

Scope of the work for installation & commissioning of WIC/WIF

- Reception of Equipments
- Identification of Refrigeration units.
- Pre-Installation Instructions
- Procedure for Installation.....
- Installation completion check
- Operating instructions
- Commissioning Report. (MONO BLOCK/SPLIT TYPE Refrigeration Units)
- User level maintenance
- Maintenance by Technicians
- PM servicing checks
- Troubleshooting Chart.....

WIC/WIF installation & commissioning.....A Turn Key Project

WIC/WIF installation & commissioning is a type of Turnkey project in which covers the following work scope (assuming all pre requisites are fulfilled)

- Walk-in-Cooler/Freezer rooms (Assembly of prefabricated panels & door)
- Fitment of Refrigeration Units
- Filling the gaps (for panel joints) with silicon sealant
- Fittings of Temperature monitoring/recording/supervising systems/Alarm systems
- Fittings of Pressure Relief Valve (in case of WIF)
- Cold/Freezer room panel fittings.
- Fitment of curtains
- Fitment of lighting.
- Laying the conduits/cable
- Assembly & fitment of shelving
- Installation & commissioning of DG set with AMF panel.
- DG set Earthing
- Installation & commissioning of Servo Controlled Voltage Stabilisers.

For users intending to conduct the installation of received cold and/or freezer rooms themselves, the Pre-Installation Guide may provide useful additional reference. It should be noted that the guide does not replace the necessity of qualified and knowledgeable personnel to conduct the installation. At the end of an installation project the Installation Check List serves as conclusive documentation and proof for completion.

In order to build local capacity in installation, use and maintenance of WIC/WIF, it is recommended to attach a training session with local technicians while the installer is present on site.

Please note, all WIC and WIF rooms should be installed with ample space to allow for sufficient air circulation and the WICs and WIFs should be protected against adverse weather conditions.

Aspects and preparations needed for installation

- Adequate floor space
- Proper ventilation (fan, exhaust fan)
- Proper flooring (foundation, platform, stands)
- Power supply with proper electrical wiring.
- Wall supports where needed

Benefits of correct installation

- Safety of equipment and user
- Reliability of equipment operation
- Performance as per expected specification
- Durability of equipment service
- Confidence in implementation of programme...

Risks of incorrect installation

- Accidents and fire
 - » Electrical short-circuits
 - » Gas leaks
- Early equipment failure
 - » increased repair / replacement cost
- Emergencies that cause disturb the programme

Notes

.....

.....

.....

.....

.....

.....

.....

.....

.....

.....



1- Reception of the equipment

1.1 Checking the equipment

At the time of delivery, check the state of the unit.

In the event of damage, address reserves to the carrier by recorded delivery within 48 hours (excluding the day of delivery and bank holidays).

The name plate shows complete reference details for the equipment, and can be used to check that the unit corresponds to the model ordered. In the case of an error or incomplete delivery, please contact manufacturer.

1.2 Handling

All unloading operations must be carried out with suitable equipment (crane, forklift truck etc...)

Removable lifting rings are available on option for certain equipment.

When using a forklift truck, the handling instructions regarding positions and direction must be respected.

The equipment must be handled with care to avoid any damage to the casing, tubes, condenser, etc...

1.3 Storage of the equipment

In case of medium or long-term storage, the following instruction must be respected:

- Leave protective and insulation devices in position.
- Check that the electrical cabinet is completely closed.
- Keep components delivered separately in a clean, dry place.
- We recommend you store the products in a dry place, under cover (obligatory for product without casing).

1.4 Technical documents

To be considered complete, this installation guide must include:

- A refrigeration circuit diagram specific to each machine.
- Technical instructions specific to each product range.
- An electrical wiring diagram specific to each machine when an electrical switching cabinet is fitted.

In case of incorrect or incomplete delivery, contact manufacturer before switching on any of these appliances.

2. Guarantee

Refer to the general terms of sale for details of the guarantee coverage.

Failure to comply with the recommendations shown in this instruction manual will entail cancellation of the guarantee.

CAUTION : In addition to the respect of this operating service guide, it is necessary to follow the legal requirements of the country where the equipment is installed.

3. Life of the equipment

The refrigerating system is designed for 10 years life if the safety and maintenance rules are strictly respected.

4. Design

The products are designed with materials and components having mechanical characteristics required to answer to the conditions of use and to the life of the equipment.

5. Safety rules

Installation and maintenance of these machines must be carried out by personnel qualified to work on refrigeration equipment. All interventions must be carried out in conformity with valid safety regulations, as well as the recommendations indicated on the labels and handbooks provided with the machine.

All action shall be taken to avoid access to not authorized people. Only skilled and authorized people can access to the machine room.

6. Layout

Check that the foundations are level, of suitable load-bearing capacity and sufficiently rigid to prevent transmission of vibrations. It is recommendable to use anti-vibration pads.

The unit must be level, in an accessible location, with sufficient clearance to carry out installation and maintenance operations without difficulty.

The requirements of national/international standard relevant to the creation of machine rooms must be respected.

The condensing units must be installed in a location guaranteeing free passage of air through the condenser and protected from all forms of pollution which could clog the coils (the leaves of deciduous trees for example).

To protect the equipment in order to avoid all risks of collision with an external element.

In case of installation in an area recognized to be risky thanks to the natural phenomena (Tomados, earthquake, short of laughed, thunderbolt.) please confirm to the standards in force and design and use the necessary devices to secure the system.

Description of identification plate for Refrigeration units.

1. Model
2. Year of manufacturing
3. Serial number
4. Type of equipment
5. Refrigerant
6. Maximum working pressure LP side
7. Maximum working pressure HP side
8. Refrigerant capacity
9. Voltage
10. Phase number
11. Frequency
12. Current and power input

To fill the installation

Check that the oil heating system works. **The casing heaters must be switched on 24 hr before starting the installation.** The equipment must be filled with refrigerant. Only the refrigerant indicated on the equipment identification plate is authorized. It is the responsibility of the contractor or installer to optimize the quantity of refrigerant. According to the type of product, pressure taps or loading valves are designed for filling and draining. The operator will take care of a correct use of these accessories during connections and disconnections operations.

The operating temperatures and pressures for the systems of refrigeration selected are Pre-Installation Instructions for WICs AND WIFs....

	R404A-R507- R407C-R22	R134A	R410A	R744
Maximum ambient operating conditions	43°C	55°C	43°C	---
Low-pressure side operating temperature (min/max)	-40°C/+43°C	-30°C/+55°C	-15°C/+43°C	-40°C/-10°C
High-pressure side operating temperature (min/max)	-10°C/+120°C	-10°C/+120°C	-10°C/+120°C	-20°C/+100°C
Low-pressure side operating pressure	19 bar	19 bar	25 bar	22 bar
High-pressure side operating pressure	28 bar	28 bar	40 bar	45 bar

Pre-installation instructions for WICs-WIFs

General

- Please ensure that the goods will be on the actual installation site within carrying distance from the final location before the arrival of the engineer (if supplier will carry out the installation)
- Storing of the goods should be done in a covered and secured area
- Please ensure that the intended installation site is cleared and ready for immediate installation to start
- The installation space should be with adequate ventilation or windows which can be opened on the top of the existing wall(s) with netting/burglar proof grills
- The crates will be opened by engineers from the supplier to verify that all pieces of equipment have arrived as packed by the supplier
- Please ensure that there is local unskilled labour available for carrying the materials and doing minor installation work such as installation of the floors, walls and ceiling panels as well as doors and shelving under the supervision of supplier engineer
- For the electrical installation it would be good to have a local electrician present to assist in the installation and final connection to the local supply network
- During installation it is preferred that all technical personnel who will be responsible for the future daily operation, maintenance and service of the room(s) will be present and participating in the installation work thereby getting a thorough understanding of the equipment.
- Concrete platform size should be according to make and model of WIC-WIF, as they are all different.
- Ensure that there is water drainage facility available from concrete platform to outside.
- Proper foundation for generator set is required, along with raised platform. It should have canopy/ protection, to protect from elements.
- Ensure that site allows smoke genset smoke exhaust through pipe.



Prefabricated rooms

- The doors of the WIC are located in the middle of one of the long walls
- There should be a free space of preferably 2.5–3 metres in the front of the door wall for easy access to the room as well as handling and possible repacking of the stored goods.
- When planning the lay-out please note that the side and back of the room can be installed within a distance of 100 mm from the exiting building wall
- Preferably installation is to be done on a levelled concrete floor
- As the rooms are made of prefabricated insulation panels the levelling / base evenness requirement is +/- 3 mm / 3 m and +/- 5 mm / 5 m
- The entrance door to the space where the installation of the room(s) is to be done should be about 900 mm wide so that panels and other pieces of equipment can be easily carried through the door opening

Electrical supply and power consumption for WICs and WIFs

- Please ensure that electricity is available in the installation premises, 380-400 V, 50 Hz, 3-phase and that there is a proper switch box/ distribution board with fuses, earthing and a main switch for the local national grid.

Procedure for installation of WICs and WIFs:

Install the Cold Room equipment without the ceiling.... Installation of panels of Floors, Walls, Corners, door. (Important: note the numbering on the panels for ensuring proper fitting)

Panel installation: Lay out floor panels based on their serial number as indicated on the layout drawing of the cold room design. Insert cam wrench into sandwich panel holes and turn cam wrench clockwise until a solid stop to form a floor. Place male bottom of

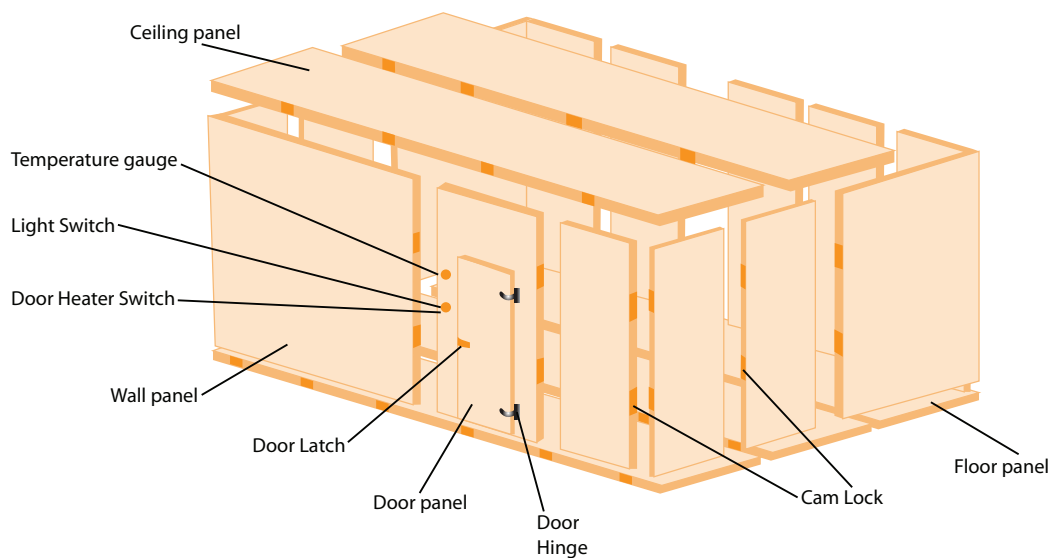

wall panel in female groove of floor panel and lock every wall panel with its adjacent floor and wall panel tightly in sequence.

- Install two refrigeration units (1 as standby)
- Install the Cold Room ceiling. (Proceed with ceiling panels as you do with floor and wall panels)
- Fix the support of the panel if any.
- Install the roof panel
- Install the cable glands
- Install the Cold Room accessories (indoor/outdoor lighting, sound alarm, locked-in personnel devise, light switch, discharge spout, thermometer)
- Fitting of floor strip and the front strip.
- Fitting of the plastic curtain on the door.
- Assembly & Fitment of shelves
- Connections of electrical equipment
- Connect the cables in the panel onto the electric terminal
- Installation of room light & connecting door heater
- In case of WIF, installation of pressure ventilator/pressure relief valve¹
- Fitting of the chart recording and other temperature monitoring devices.

1 = A freezer room should be fitted with a pressure release vent. The pressure release vent is required for rebalancing the pressure, in case negative pressure builds in the freezer room.

Typical installation pictures for WIC-WIF



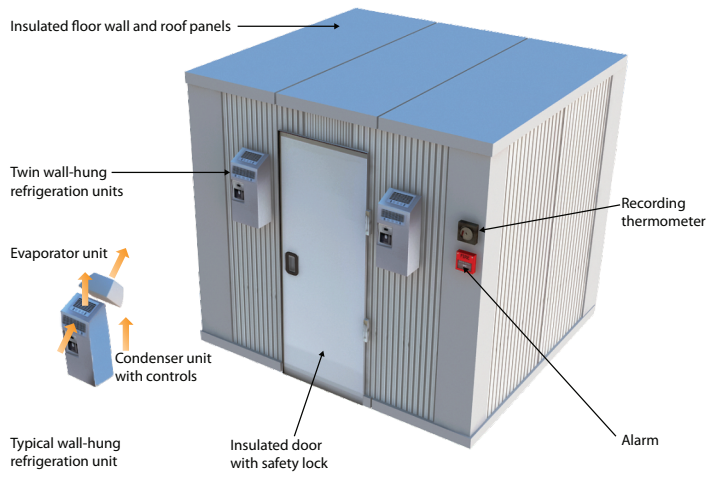
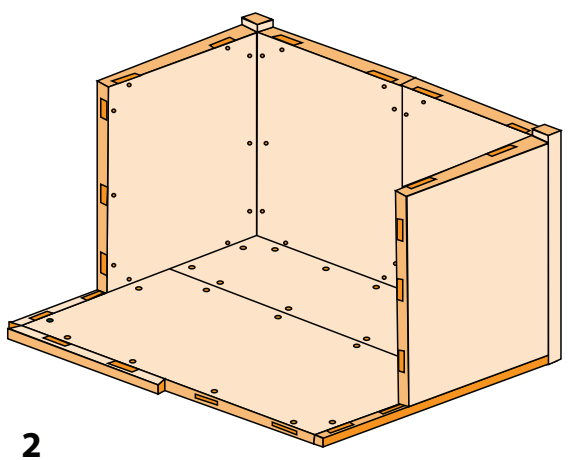
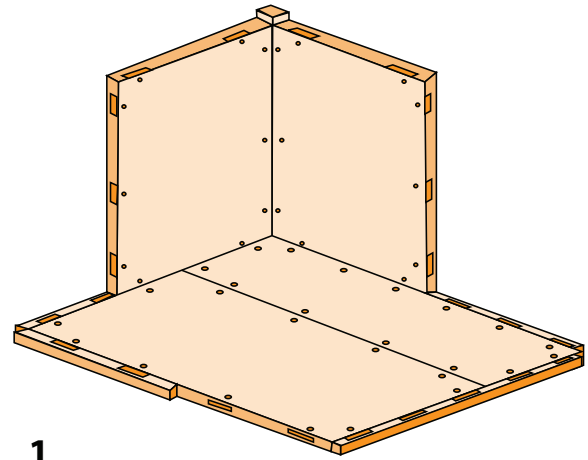
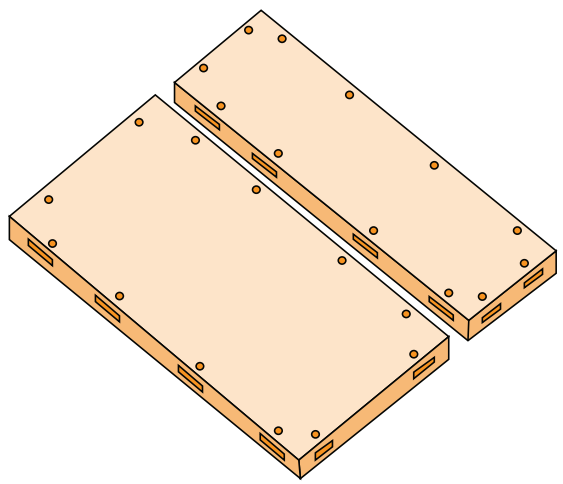
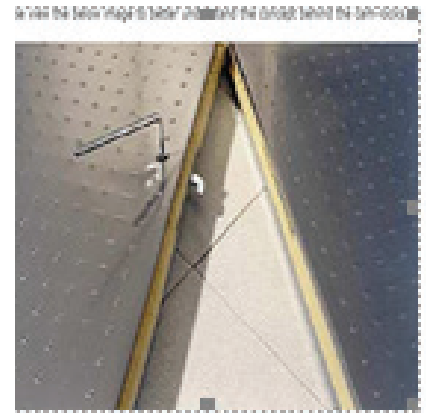
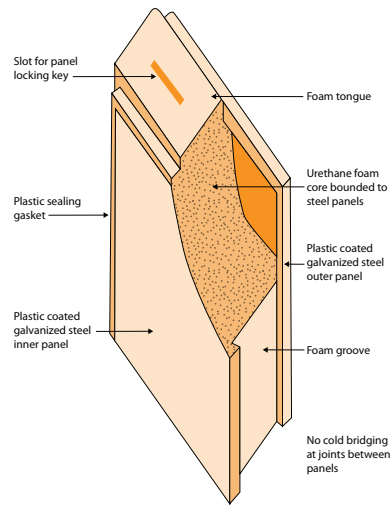

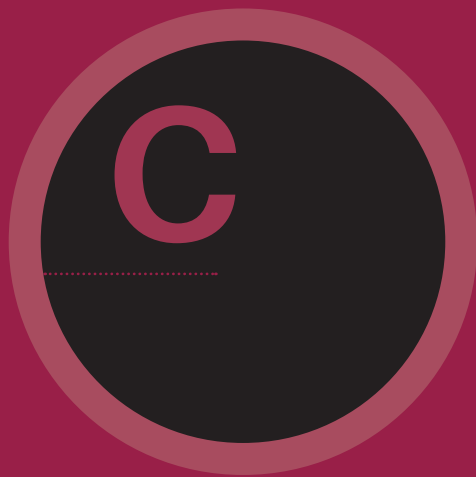

Sample block
diagram sequence
for interconnection
of WIC/WIF
components



CONTROL UNITS & INTERCONNECTIONS:

COLOUR CODE OF CABLE TO BE FOLLOWED:

- BLACK(BK) = L1 (R)
- BROWN(BN) = L2 (S)
- WHITE(W) = L3 (T)
- BLUE(B) = N (N)
- YELLOW/GREEN = PE (E)

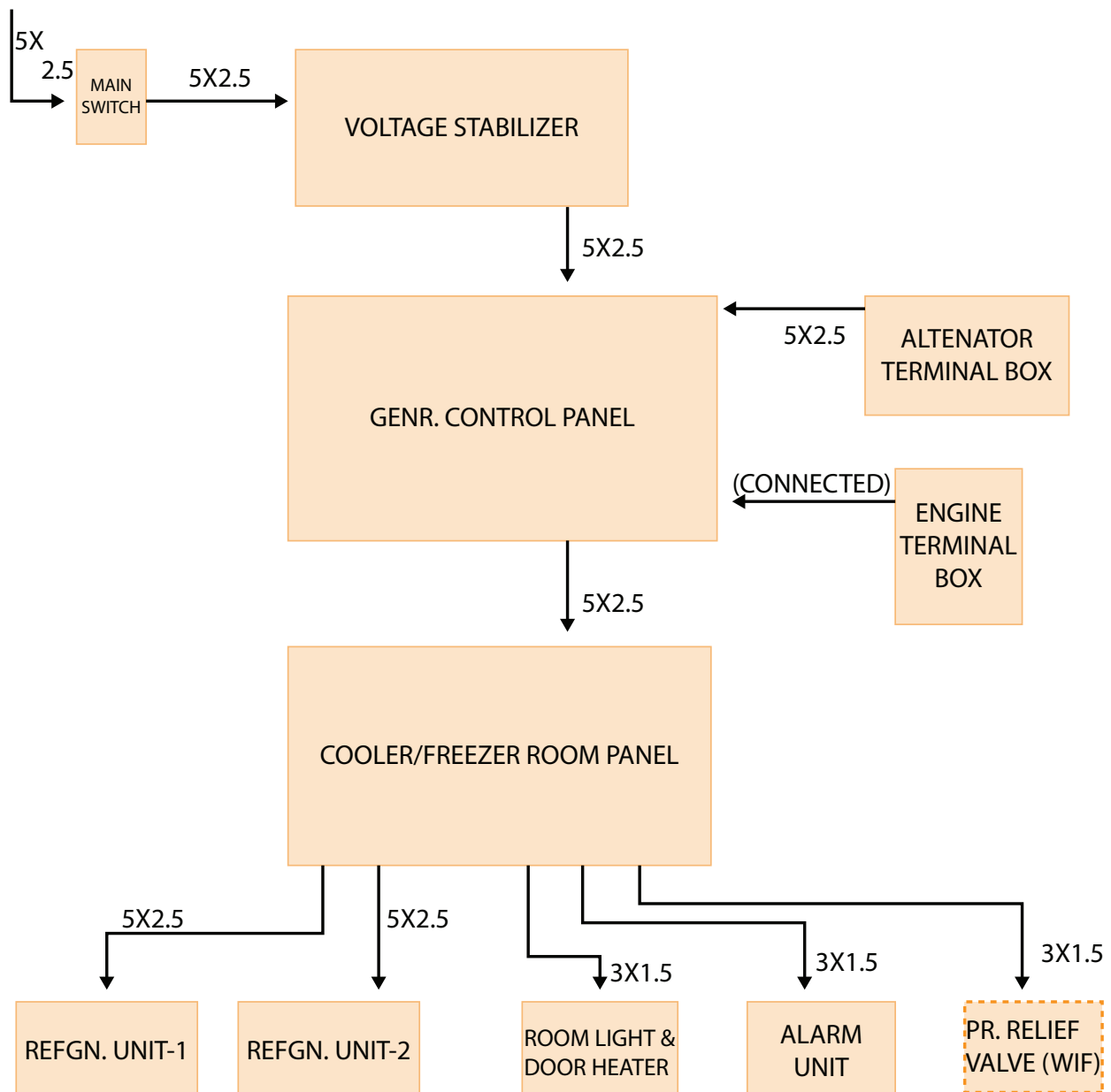

Following Indicative diagrams are useful for site planning/assessment to be conducted by installer

The diagram gives brief information about.....

- Internal & external dimensions for WIC model
- Concrete floor base dimensions
- Requirement of front/rear & side clearances
- Insulation thickness
- Location of components
- Concrete base dimensions for DG set
- Location of Interfacing equipments, i.e. DG set & Servo Stabiliser

Mono Block Refrigeration Units

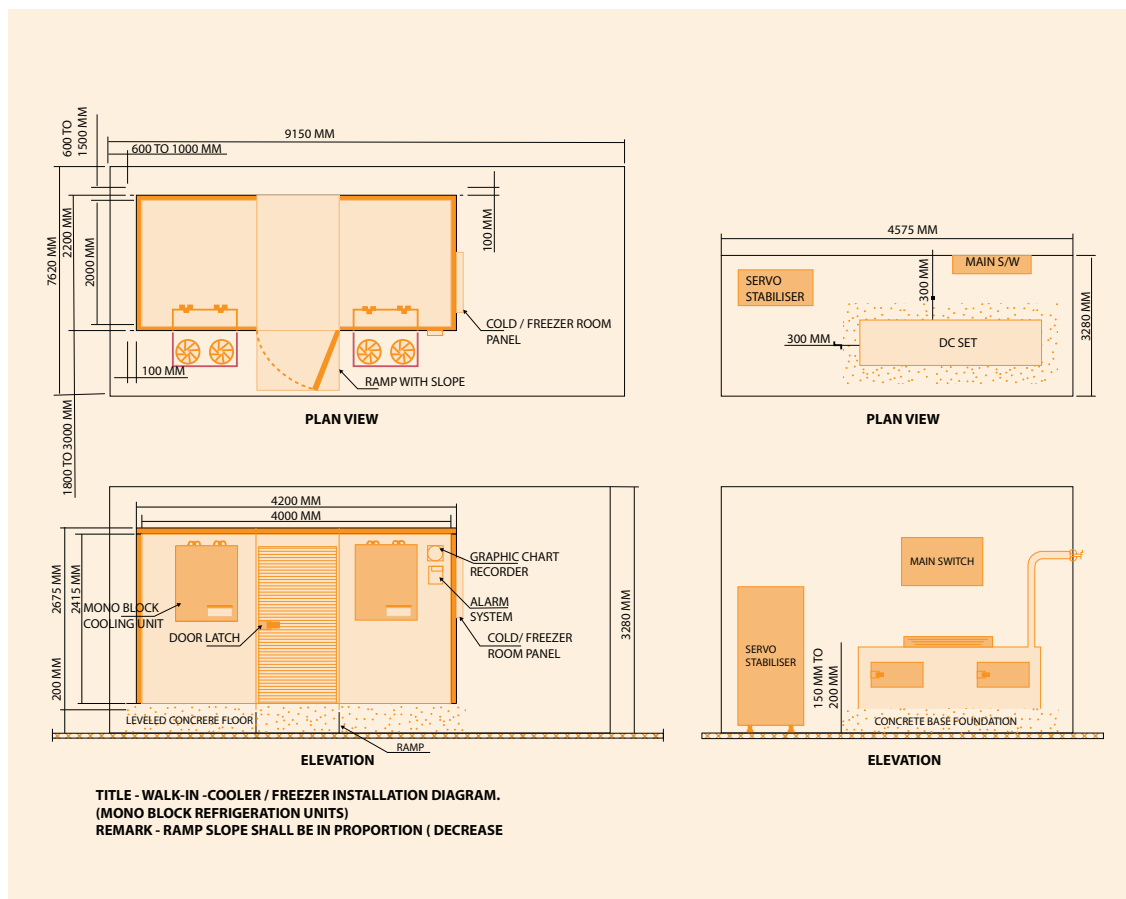

Drawing Notes.....Please refer the diagram.

- For Mono block cooling units WIC/WIF the size can be accommodating is up to 40 CBM with minimum clearances mentioned at front/rear & side of the levelled concrete foundations. (Haier 40 CBM model is exception as it is more in width)
- These clearances may vary according to make and model of WIC-WIF, as they are all different.
- Here the WIC cubic capacity considered is 20 CBM.

Split systems Refrigeration Units

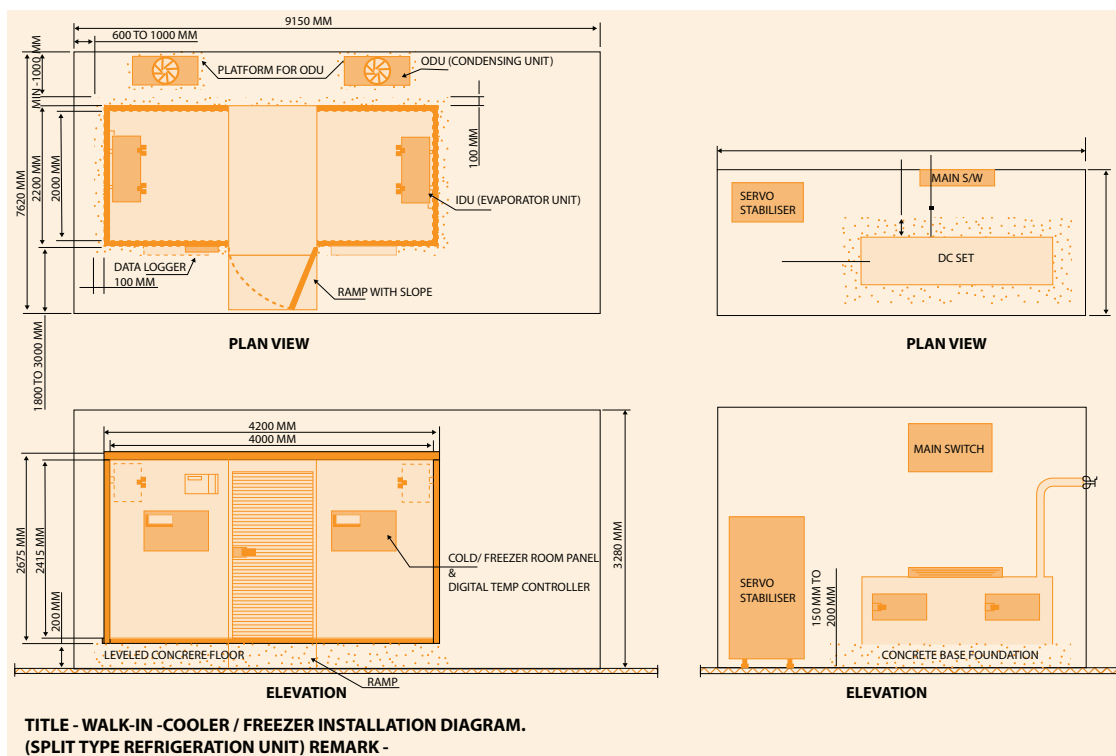

- The split system refrigeration units can be used in the same available space where ventilation is inadequate or temperature is high.
- For the split system refrigeration units, the clearance of 1500mm is recommended at rear portion of WIC/WIF.
- Condensing unit should be preferably on the platform on the back side of the WIC/ WIF.
- Here the WIC cubic capacity considered is 20 CBM.

NOTE

For both type of installations, the lay out can be changed depending upon the site condition, but overall dimensions should remain same.

Installation completion check for WICs AND WIFs

Note: Complete a copy of this schedule for each Cold room or Freezer room on the site.
Pre-completion checklist Date:

Country:

City/town:

Site name:

Room description:

All checks must be satisfactory before final handover acceptance.

TEST 1 - Inspection

General

All components are undamaged. **Yes/ No**

Descriptive Comments on status/condition of parts on arrival before installation:

Room enclosures:

1. All room enclosures have been installed and are of the correct size (m³).

Yes/No

2. Wall, floor and ceiling finishes are as specified in the PQS/ ITB.

Yes/ No

3. All enclosure panel joints are tightly butted together.

Yes /No

4. There are no gaps around panel cut-outs where refrigeration units and services penetrate the enclosure(s).

Yes/No

5. There are no gaps around room door seals. Catches and locks operate freely

Yes/ No

6. Door seal heater elements (where specified) are fitted. N/a

Yes /No

7. Freezer room pressure relief vents are fitted and operate correctly.

Yes/ No

8. Internal tungsten lighting has been fitted, operates correctly and produces the specified minimum lighting level throughout the room.

Yes /No

9. Shelving units are of the specified size, material and have been set up with adjustable shelves correctly spaced.

Yes /No

10. Enclosures are marked with the correct temperature zone symbol sticker.

Yes /No

11. Heater mats (where specified) have been fitted under floor panels and operate correctly N/a

Yes/ No

Give a short descriptive Comment on above questionnaire:

Refrigeration and temperature monitoring equipment:

12. Automatic/Manual duty-sharing circuits are installed and operate correctly.

Yes /No

13. Refrigeration units are marked with the correct refrigerant identification.

Yes/ No

14. Evaporator cages or deflectors (where required) have been installed. N/a

Yes /No

15. Temperature recording units and sensors are correctly located.

Yes/ No

16. Acoustic and/or visual alarm units are correctly positioned.

Yes/ No

17. All electrical cables are securely clipped in place and electrical cover plates and accessories are securely fixed.

Yes/ No

18. All components that require routine servicing or replacement are easily accessible.

Yes/ No

19. All components are correctly protected against the weather or other environmental conditions.

Yes /No

Comments:

20. Test recommendation:

Pass /Fail

TEST 2: Cool down

21. Number of hours for the WIC/WIF to reach +4°C/-15°C

22. Test 2 recommendation:

Pass/ Fail

23. Training course(s)

24. Training on Maintenance for technicians recommended:

Yes/ No

Give a brief description for the reason to arrive on the above recommendation

25. Overall conclusions and recommendations on installation and commissioning

Recommendation:

Pass /Fail

If FAIL, list outstanding work still required:

- A) B)
- C) D)

If PASS, the installation can be handed over to the user.

Installation technician's Signature:

Date:

Consignee's Signature:

Date:

Operating instructions

Warning and Safety Information

The machine must not be operated without the originally safety features installed: Electrical protection, pressostats, thermostats, ventilation grilles, etc. These devices must be kept in working condition and the pictograms displaying the hazards must remain visible.

Check-out before start-up

Make sure that

- Dedicated power supply should be provided for the cold room plant and should not be shared with other electrical apparatus.
- Ground wire must be properly connected to electrical cabinet screws for protection against shock hazard. Ground insulation resistance must be over 2 mega ohm.
- All electrical terminals are correctly tightened.
- All valves are set properly for efficient operation.
- Power voltage is within 10% of that indicated on the condensing unit nameplate.
- Cold room ambient temperature range is 5°C to 40°C
- Oil level is at the designed limits. Monitor the oil level in the compressor during first few hours of operation (between 1/4 and 3/4 in sight glass).
- Top up refrigerant & oil level if necessary.
- No flammable or explosive material should be placed in the vicinity of this appliance.
- Excess oil could result in damage to the compressor. (valve damage)
- Thermostat and other control units of the cold storage room are properly set.
- Check & Record the following values
 - » Compressor operating range
 - » Power supply (See name plate)
 - » Input amperage of Compressor & fan motors
 - » Pressure on suction & discharge

Start-up

Walk-in coolers and walk-in freezers are automatic control system design. Start-up is simply a press of ON button.

After Start-up

Do not touch any electrical components except operating parts.

Avoid touching air-cooled condenser and fan with hands or with other objects when they are in operation.

Avoid touching compressor, discharge line and condenser in case of scald when in operation.

Do not adjust safety control settings when machine is in operation for prevention of unit damage of the cold storage room.

Make sure all power sources are disconnected before any circuit check-up.

When unusual noise happens during operation, stop machine immediately and take corrective action.

When walk-in cooler and walk-in freezers are off-work for a long period of time, main power supply should be shut down.

Operational check-out

- Compressor should not be forced to stop before it operates at least three minutes, and vice versa reset cannot be done until 3 minutes after shut-down. Frequent start-ups are not acceptable and there should be no more than 5 times per hour.
- The oil level should be at or slightly above the center of the sight glass at normal operation conditions. If the oil level is low, more oil of the same type should be added to bring the level up.
- Observe the condition of moisture in the liquid line sight glass. When moisture content level is over system limits, replace filter-dryer. The relations between liquid line sight glass colour and moisture content level:
 - » Blue: low, normal
 - » Violet: slightly high, replacement of filter-dryer is recommended
 - » Purple: high, alarm limits, replacement of filter-dryer is necessary
 - » Rosiness: seriously high
- NOTE: If refrigeration system repair needs adding more refrigerant, replace the filter-dryer before adding.
- Inspect operational conditions of compressor, condenser and fan motor for loose screws and unusual noise. Tighten or stop and repair.
- Check piping insulation for prevention of refrigerated air loss.

Commissioning of WIC-WIF

Recommended Tests:

- Running test -
- Power consumption test
- Cool-down time
- Temperature mapping test
- Control and monitoring equipment tests
- Stand-by generator operation test.

Notes

.....

.....

.....

.....

.....

.....

.....

.....

.....

.....

WIC/WIF Commissioning Report. (MONO BLOCK Refrigeration Units)

State: _____ District: _____ Date: ___ / ___ / _____

Cold Chain Facility: _____ Level: State / Regional / Divisional

Make _____ Model _____ Equipment Serial No _____

Room description: _____

Date of Commissioning ___ / ___ / _____ Date of Handing over to consignee ___ / ___ / _____

Sr.no.	Ref. Unit I		Ref Unit II	
	Type	Model	Type	Model
1	Monoblock		Monoblock	

OPERATING PARAMETERS:

Voltage R.....Y.....B.....

* Ambient Temp during Commissioning.....°C

* Box Temp. as per order.....

* RH as per order.....%

* Actual RH achieved.....%

* Defrost Setting..... No. of Cycles.....

* Compressor Suction Pressure.....psig

* Compressor Amps: R.....Y.....B.....

* Evaporator Drain Line Heater for Freezer provided

* Door Heater & pressure relief valve tested (If freezer)

* Drain Trap provided

* Safety Controls tested

* CC Heater (If any)

* Temp recorder/Data Logger parameter set & tested

* Alarm/Hooter system set & tested

* Single Phase Preventer/phase reversal protection

* Stabilizer attached & tested & working

* Ref.duty sharing on thermostatic control

* Liquid line Size Dia.....(inches)

* Suction pipe size Dia..... (inches)

* Actual Box Temp. Achieved.....°C

* Insulation Thickness..... (mm/inches)

* Thermostat Setting.....°C

Duration: Minutes.....

* Compressor Discharge Pressure.....psig

Yes [] No []

Yes [] No []

Yes [] No []

Yes [] No []

Yes [] No []

Yes [] No []

Yes [] No []

Yes [] No []

Yes [] No []

Yes [] No []

Name.....Signature.....Date.....

(Engineer-Installation Agency)

WIC/WIF Commissioning Report (SPLIT TYPE Refrigeration Units)

State: _____ District: _____ Date: ___ / ___ / _____

Cold Chain Facility: _____ Level: State / Regional / Divisional

Make _____ Model _____ Equipment Serial No _____

Room description: _____

Date of Commissioning ___ / ___ / _____ Date of Handing over to consignee ___ / ___ / _____

Sr.no.	Ref. Unit I		Ref Unit II	
	Type	Model	Type	Model
1	IDU		IDU	
2	ODU		ODU	

OPERATING PARAMETERS:

- * Voltage R.....Y.....B.....
- * Ambient Temp during Commissioning...°C
- * Box Temp. as per order.....°C
- * Actual Box Temp. Achieved.....°C
- * RH as per order.....%
- * Actual RH achieved.....%
- * Thermostat Setting.....°C
- * Insulation Thickness.....(mm/inches)
- * Defrost Setting.....No. of Cycles.....Duration: Minutes.....
- * Compressor Suction Pressure.....psig
- * Compressor Discharge Pressure.....psig
- * Compressor Amps: R.....Y.....B.....
- * Total Refrigerant Piping Length.....(Feet)
- * Liquid line Size Dia.....(inches)
- * Suction pipe size Dia..... (inches)
- * Condensing Unit Location Above [] Below []
- * Height Difference..... (Feet)
- * Evaporator Drain Line Heater for Freezer provided Yes [] No []
- * Door Heater & pressure relief valve tested (If freezer) Yes [] No []
- * Drain Trap provided Yes [] No []
- * Safety Controls tested Yes [] No []
- * CC Heater (If any) Yes [] No []
- * Temp recorder/Data Logger parameter set & tested Yes [] No []
- * Alarm/Hooter system set & tested Yes [] No []
- * Single Phase Preventer/phase reversal protection Yes [] No []
- * Stabilizer attached & tested & working Yes [] No []
- * Ref.duty sharing on thermostatic control Yes [] No []

Name.....Signature.....Date.....

(Engineer-Installation Agency)



User level Routine Maintenance

Keep the space outside the room cool

Keep the space outside the cold room or freezer room as cool as possible. Condenser units give off a considerable amount of hot air. If this hot air is not removed from the environment, the efficiency of the cooling units is reduced. Trees or screens help to shade the building that houses the cold store. Good ventilation removes the hot air. Alternatively, air conditioning may have to be used to keep the space cool.

Keep the condenser unit well ventilated

Do not allow rubbish and packaging to accumulate in the vaccine storage area. It is essential to maintain free air movement around the condensing units.

Carry out minor maintenance:

- Clean the room
- Adjust thermostat if required.
- Check lock and hinges of door.
- Manual defrosting if needed.

Maintain the standby generator:

- Keep battery charged.
- Keep diesel tank full.
- Run the generator every week.
- Maintain log book.

Know where switches and fuses are:

Find out where the main switch and electrical fuses are. Make sure that you have spare fuses and know how to fit them.

Know your change over switch and control panel of generator:

Find out what is the maximum permissible ampere. Call technician when ampere shows more than permissible limit.

Know your service provider/agency and update the AMC with full clarifications.

Find out the name and telephone number of the service agency and/or the telephone number of the maintenance technician. Have the numbers ready for use in case of emergency.

Listen to the cooling equipment

Listen to the cooling equipment when it is working correctly. This helps you to know what normal working sound is and identify faults before they become too serious. Cooling equipment runs more often during the hot season than during cooler periods. In cold weather it may run very infrequently. The running time of the cooling equipment increases if the door is opened frequently.

Learn about the working of the automatic changeover system.

Generally this is set up so that one cooling unit runs for 24 hours and another takes over for the following 24 hours. This is known as duty sharing and ensures that both units get the same amount of use.

Notes

Area with horizontal dashed lines for taking notes.

Daily Checks

Temperature: Auto temperature recording and twice a day

- Check the temperature of the WIC/F twice each day.
- Cold rooms must be kept between +2°C and +8°C.
- Freezer rooms must be kept between -15°C and -25°C.
- Maintain logbook if automatic system does not work

Check inside the WIC/F.

- Is the airflow from the evaporator normal?
- Is the evaporator fan running quietly?
- Is there water on the floor? If there is, the evaporator drainpipe may be blocked.

Check outside the WIC/F.

- Remove any rubbish.
- Check for signs of vermin such as cockroaches, mice, rats and bats.
- Clean the floor twice a week.

At the end of the day make sure that:

- All lights in the WIC/F are switched off;
- There is nobody inside the WIC/F;
- The door to the WIC/F is closed and locked.

Weekly checks

Change the temperature chart

If you have a chart recorder with a paper disc, change the disc at the end of each week. Write the start date on the new chart. Write the finish date on the old chart and keep it safely in a file for at least 12 months. If the recorder is operated by clockwork, wind up the mechanism. Refill the ink containers and check the pens.

1. Change the refill/pen if needed.
2. Set the thermostat if needed

Check the liquid sight glasses:

If the cooling units have accessible sight glasses, check that both are filled with liquid and show "dry" conditions. If you see bubbles, there may be a leak of refrigerant. If the moisture indicator shows "wet", the filter drier probably needs changing. Ask the service agency or maintenance technician to check and replace it if necessary.

Check ice build-up on the evaporator

Check the ice formation on the evaporators. Look at the pipes and fins. Most modern cooling units have an automatic defrosting system.

If they are coated with ice more than 6 mm thick, the evaporator needs defrosting and there could be a defect in the defrosting system.

Ask the service agency or maintenance technician to check.

Check the alarm system.

Check the alarm system functionality. The alarm should sound in case of temperature breaches. If it does not, then alarm system may be faulty. Ask the service agency or maintenance technician to check it immediately.

Check the store

- Stack as per EEFO/FIFO
- Check VVM
- Check most freeze sensitive vaccine, are they frozen!!

Run the stand by Generator.

- Check the oil and fuel levels and fill up if necessary.
- Check the battery electrolyte level if the battery is of the open type.
- Run the generator until it has warmed up and make sure that it is operating correctly.

Monthly checks

Check the room enclosure:

Check the WIC/F enclosure every month to make sure there are no major problems.

Check the panels

- Check the bottoms of the panels to see if there are any signs of rust.
- Rust may occur if the panel coating is damaged and if water is left after the floor has been washed and that collects under the floor panels.
- Inspect the panel joints internally and externally. There should be no evidence of movement along the joint lines and no sign of condensation or ice build-up. If the joints are not tight and well sealed the panels may absorb moisture. This reduces the efficiency of insulation. Furthermore, moisture may freeze inside the joints and force the panels apart.
- Inspect the area around the evaporator. This is usually the coldest part of the room. If there is ice or condensation on the panels, one or both of the following factors (door and strip curtain) could be responsible.

Check the door

Go inside the room and ask a colleague to close the door from outside.

- Test the action of the internal safety release handle. Does it work properly? If not, call the maintenance technician.
- A WIF should have an electrically heated door seal. If the door seal heater is not working the door may freeze shut. If the door is difficult to open and there is ice around the door seal, the heater may not be working. Call the maintenance technician
- A WIF should be fitted with a pressure release vent. Every time you enter the WIF you let in a certain amount of warm air. When this cools it contracts and negative pressure begins to build up inside the room. The pressure release vent then opens and allows enough outside air to enter and rebalance the pressure. However, if the pressure release vent is blocked, the negative pressure remains, and the door becomes very difficult to open. If the door is difficult to open, check the release

vent to see if it is iced up. Remove the ice if you can. If you cannot do this, call the maintenance technician.

Check the strip curtain

An internal plastic curtain reduces

1. The amount of humid air that enters the WIC/F,
2. The amount of cold air that escapes when the door is opened. If plastic curtain is fitted, check to ensure that it is undamaged. If it is damaged, instruct the maintenance technician to replace it.

Check stock, any vaccine stored for more than recommended period.

Monitor routine and emergency maintenance

Ensure that the service agency or maintenance technician carries out all routine servicing as recommended by the manufacturer(s) within warranty period and under the AMC of the WIC/F and the cooling and monitoring equipment. Ensure that you receive a copy of the service checklist as evidence that the work has been correctly done.

- Some of the necessary routine checks are:
- Oil and refrigerant leak check;
- Drive belt tension check;
- Routine cleaning of compressor components, including the condenser coil and fins;
- Check the foundation bolt of compressor.
- Door seal check;
- Temperature control check, using the temperature charts as evidence;
- Replacement of components before failure occurs as part of a planned preventive maintenance (PPM) regime.
- Check the lubrication oil of Generator and service it if needed.

Notes

.....

.....

.....

.....

.....

.....

.....

.....

.....

.....

.....

.....

.....

.....

.....

.....



Maintenance by Technicians.....

Maintenance recommendations

One time a year:

- Visual monitoring of the installation to detect the traces of shocks, corrosion, leak of refrigerant and oil
- Pressures and temperature operating range.
- Compressor pressures and temperatures (operating range).
- Input amperage for the compressor and the fan motors.
- Cut-out points on HP/LP safety switches.
- The setting values of control devices.
- Safety devices (cooling, electrical, etc.).
- Oil levels.
- Analysis of oil (acidity factor).
- Oil change if necessary, in accordance with manufacturer's recommendations.
- Replacement of dryer cartridges and filters in case of humidity.
- Humidity in the circuits (using sight glass or oil analysis).
- State of hoses.

- Refrigerant circuit sealing.
- Clogging up of the condenser coil (condensing unit).
- Cleaning of the condenser coil (condensing unit).

Protect motors with plastic film.

Clean regularly using a mild detergent (without chlorine or ammonia) and rinse the coil with clear water (maximum pressure 3 bar, jet pointing at the edges of the fins). Dust must be removed from the coil as soon as possible. Exchangers installed in a corrosive environment must be cleaned frequently using fresh water (for maximum coil life).

- Crankcase heater in good working order.
- Tightness of electrical connections.
- Compressor fastening elements, supports and connection tightness.
- Vibration and movement due to temperature or pressure changes.
- State of the thermal insulation and possible corrosion.

One time every five years.

- In addition to the annual checks, it is proceeded to:
Checking of the damaging of the equipment due to the vibration.

One time every eight years:

- In addition to the annual checks, it is proceeded to:
The certification of the safety devices.

Notes

Area for handwritten notes with horizontal dashed lines.



PM SERVICING CHECKS

(For Daily, Weekly, Monthly, Quarterly and Annual Cycle)

Servicing for Walk-in-Cooler/Freezer _____ on date _____

Sr. NO.	DESCRIPTION	NAME & SIGNATURE	JOBEXPLANATION/REMARKS
I. Walk-in-Cooler/Freezer			
Daily			
1	Check and ensure no leakage of oil for each compressor.		
2	Check and ensure all refrigerant level for each system (should a shortage appear, the fault must be resolved before charging refrigerant)		
3	Check for ice forming at evaporator (the fault must be clarified, before manual defrost is performed)		
4	Check for Pressures in the refrigeration systems.		
5	Check WIC/WIF temperature monitoring including proper functionality of digital temperature controller		

Monthly			
1	Carry out all daily tasks accordingly.		
2	Check and ensure condenser coil fins cleanliness to ensure efficiency of the system.		
3	Check and ensure unit cooler fan and evaporator cleanliness. Clean if necessary to ensure efficiency of the system.		
4	For each cooling-unit in full-load. <ul style="list-style-type: none"> ▪ Low pressure ▪ High pressure ▪ Amperage compressor. 		
5	Check and ensure all refrigerant levels for each compressor and charge if necessary as per manufacturer's specification (As all the system are sealed, only in case of mall function the refrigerant can escape, (The leak must be repaired; a pressure check with nitrogen and vacuum check must be done before charging refrigerant.)		
6	Check and ensure proper functionality of control valve For the dx-system the superheat and solenoid valve must be checked		
7	Check and ensure proper functioning of defrosting function and depend which type of defrost method is used, check functionality of heating elements based on power consumption,		
8	Check and ensure proper functions of Data logger's batteries, software, memory, and backup data and SMS indicator if any. Rectify or replace accordingly. (Battery can only be changed under power. First a backup must be generated before this action)		
9	Perform full functional test for all the whole system.		
Quarterly			
1	Carry out all monthly and daily tasks accordingly.		
2	Check for sign of deterioration, condensation and proper functionality for all electrical connections up till the main switchboard.		
3	Carry out calibration of digital thermometer with correction of not more than $\pm 0.5^{\circ}\text{C}$		
Annually			
1	Carry out all daily, monthly and quarterly tasks accordingly.		
2	Perform complete servicing on for both refrigeration units.		
3	Maintain a hardcopy record for service department & auditing purpose.		
4	TEMP MAPPING ¹		

WIC/WIF PREVENTIVE MAINTENANCE..... CHECKLIST FOR TECHNICIANS

State: _____ District: _____ Date: ____ / ____ / ____

Cold Chain Facility: _____ Level: State / Regional / Divisional / District _____

Equipment: _____

Make _____ Model _____ Equipment Serial No _____

Sr. No.	Item Description	YES	NO	Readings (Where read)
A. POWER SUPPLY AND GENERATING SET				
1	Mains Power supply voltageOK.	Yes <input type="checkbox"/>	No <input type="checkbox"/>	
2	Power supply switches and fuses are healthy.	Yes <input type="checkbox"/>	No <input type="checkbox"/>	
3	Standby generator connection.....OK.	Yes <input type="checkbox"/>	No <input type="checkbox"/>	
4	Battery in good condition.	Yes <input type="checkbox"/>	No <input type="checkbox"/>	
5	Battery acid specific gravity.....OK.	Yes <input type="checkbox"/>	No <input type="checkbox"/>	
6	Battery electrolyte level proper.	Yes <input type="checkbox"/>	No <input type="checkbox"/>	
7	Battery firmly fitted to the frame.	Yes <input type="checkbox"/>	No <input type="checkbox"/>	
8	Battery terminal connections proper.	Yes <input type="checkbox"/>	No <input type="checkbox"/>	
9	Engine lube oil level correct.	Yes <input type="checkbox"/>	No <input type="checkbox"/>	
10	Any visible leakage of engine lube oil.	Yes <input type="checkbox"/>	No <input type="checkbox"/>	
11	Generator has sufficient fuel in the tank.	Yes <input type="checkbox"/>	No <input type="checkbox"/>	
12	Any visible leakage of fuel.	Yes <input type="checkbox"/>	No <input type="checkbox"/>	
13	Reserve fuel in stock.	Yes <input type="checkbox"/>	No <input type="checkbox"/>	
14	Generator clean from dirt & dust.	Yes <input type="checkbox"/>	No <input type="checkbox"/>	
15	Generator firmly placed (Mounted with Anti vibration pad) on the floor.	Yes <input type="checkbox"/>	No <input type="checkbox"/>	
16	Stop solenoid pulls in the plunger fully when "stop" button is presses (for diesel generator only)	Yes <input type="checkbox"/>	No <input type="checkbox"/>	
17	Generator can be started manually.	Yes <input type="checkbox"/>	No <input type="checkbox"/>	
18	Generator can be stopped manually.	Yes <input type="checkbox"/>	No <input type="checkbox"/>	
19	Generator starts automatically in case of mains power failure (Check on Test mode)	Yes <input type="checkbox"/>	No <input type="checkbox"/>	
20	Generator stops automatically when mains power restored (Check on Test mode)	Yes <input type="checkbox"/>	No <input type="checkbox"/>	
21	Generator out-put voltage correct?	Yes <input type="checkbox"/>	No <input type="checkbox"/>	
22	Generator lube oil pressure correct?	Yes <input type="checkbox"/>	No <input type="checkbox"/>	
23	Cooling unit run from generator power.	Yes <input type="checkbox"/>	No <input type="checkbox"/>	

24	Generator start/run amps is as per the rating of cooling units when working from generator supply.	Yes <input type="checkbox"/>	No <input type="checkbox"/>	
25	Generator coupling and alignment is proper.	Yes <input type="checkbox"/>	No <input type="checkbox"/>	
26	All the exhaust goes out of the room.	Yes <input type="checkbox"/>	No <input type="checkbox"/>	
27	Generator room clean and airy.	Yes <input type="checkbox"/>	No <input type="checkbox"/>	
28	All cable terminals to generator are firm on their positions.	Yes <input type="checkbox"/>	No <input type="checkbox"/>	
29	Any abnormal noise in generator set.	Yes <input type="checkbox"/>	No <input type="checkbox"/>	
30	Any abnormal noise in control panel.	Yes <input type="checkbox"/>	No <input type="checkbox"/>	
31	Oil filter needs replacement? (Also verify the maintenance schedule of manufacturer)	Yes <input type="checkbox"/>	No <input type="checkbox"/>	
32	Air filter needs cleaning or replacement? (Also verify the maintenance schedule of manufacturer)	Yes <input type="checkbox"/>	No <input type="checkbox"/>	

B. REFRIGERATION UNITS AND COLD ROOM

1	Refrigeration unit no.1 is working (Trouble free Normal Operation)	Yes <input type="checkbox"/>	No <input type="checkbox"/>	
2	Refrigeration unit no.2 is working (Trouble free Normal Operation)	Yes <input type="checkbox"/>	No <input type="checkbox"/>	
3	Units interior clean.	Yes <input type="checkbox"/>	No <input type="checkbox"/>	
4	Units condenser coils and fins clean.	Yes <input type="checkbox"/>	No <input type="checkbox"/>	
5	Apparent leakage of refrigerant from the system.	Yes <input type="checkbox"/>	No <input type="checkbox"/>	
6	Heavy frosting on evaporator coils (Visual Checks)	Yes <input type="checkbox"/>	No <input type="checkbox"/>	
7	Evaporator fans working properly.	Yes <input type="checkbox"/>	No <input type="checkbox"/>	
8	Condenser fan working properly.	Yes <input type="checkbox"/>	No <input type="checkbox"/>	
9	A unit start and goes off properly, as per the set temperature (Cut in-Cut off values) & working within specified range of set temp.	Yes <input type="checkbox"/>	No <input type="checkbox"/>	
10	Any abnormal noise in the compressor	Yes <input type="checkbox"/>	No <input type="checkbox"/>	
11	Any abnormal noise in the Refrigeration unit	Yes <input type="checkbox"/>	No <input type="checkbox"/>	
12	Defrost drainage pipe connected properly	Yes <input type="checkbox"/>	No <input type="checkbox"/>	
13	Leakage in joints of panels...(Cooling Loss observed)	Yes <input type="checkbox"/>	No <input type="checkbox"/>	
14	Door closing properly without gap.	Yes <input type="checkbox"/>	No <input type="checkbox"/>	
15	Lock on door is intact & functions properly. (From inside & outside)	Yes <input type="checkbox"/>	No <input type="checkbox"/>	
16	Wall mounted thermometer present	Yes <input type="checkbox"/>	No <input type="checkbox"/>	
17	Alarm system working properly. (In case of excursion of cold/freezer room temperature.)	Yes <input type="checkbox"/>	No <input type="checkbox"/>	
18	Temperature recorder working properly	Yes <input type="checkbox"/>	No <input type="checkbox"/>	
19	Past temp recorder charts preserved properly	Yes <input type="checkbox"/>	No <input type="checkbox"/>	
20	Present temp recorder chart, correctly set for date and time	Yes <input type="checkbox"/>	No <input type="checkbox"/>	
21	Temp recorder chart advancing with time.	Yes <input type="checkbox"/>	No <input type="checkbox"/>	
22	Present temperature recorded is as per the actual cold/freezer temperature observed.	Yes <input type="checkbox"/>	No <input type="checkbox"/>	
23	Thermostat/Temperature Controllers on units are working properly	Yes <input type="checkbox"/>	No <input type="checkbox"/>	

C. Any other specific observation / remarks /repairs done/ spares fitted (write in details)

Technician:

Date:

Place:

Troubleshooting Chart.....

Most Common Faults with likely causes & adapted corrective action

Problem	Likely Cause	Recommended Action
I-1. Compressor Doesn't Start	No Power Supply	Check the general supply & state of Switches
	Motor Burnt out	Replace the motor
	Fuses blown	Examine the cause-Remedy it & change the fuses.
	Voltage too low	Check the supply voltage
	Anti short cycle relay tripped	Wait for end of time delay.
I-2. Compressor Starts	Oil Pressure switch tripped	Check the condition of oil pressure switch
		Check the differential oil pressure
		Check the oil filter.
	LP too low	Check evaporator Pressure
		Check condition & differential of LP pressure switch
	HP too high	Check condenser pressure
		Check condition & differential of HP pressure switch
	Compressor Thermal Overload Relay Tripped	Check Relay condition & replace if necessary
		Check Suction superheat on suction
		Check phase balance
		Check ohmic values of motor windings
	Compressor Thermal Overload Relay Tripped	Check absence of liquid return
Check HP pressure		
Power supply protection tripped	Check supply voltage (2 phase)	
	Check Condition of motor windings and replace compressor if necessary.	
	If the compressor is mechanically jammed, replace it.	
I-3. Compressor has difficulty starting up	Faulty coupling	Check coupling
	Faulty windings	Replace the compressor
	Mechanical incident	Replace the compressor
	Oil level too high	Drain off excess oil
	Presence of liquid	Lock compressor and start up crankcase heater
I-4. Compressor runs continuously	Regulation system or other automation fault on cooling circuit controls	Check operation of cooling circuit regulation
	Evaporator(s) supply problem	See II
I-5. Unusual Compressor noise. Caution: If the compressor makes an unusual noise, stop it immediately and solve the problem before starting up again	Mechanical incident	Seek cause of breakdown, replace the compressor
	Liquid in the suction line Emulsion in the crankcase	Examine and adjust expansion valve (s) Check that liquid solenoid valve(s) do not remain open when unit stopped
	Compressor valves not watertight or broken	Replace faulty parts
I-6. Power is on, but control board does not display	Phase loss or fuse blown	Check wiring for breaks and replace fuse
	Power phase open or transformer shorted	Check Transformer output voltage (if any)
	Control board failure	Replace cold storage room control board

Problem	Likely Cause	Recommended Action
I-7. Control board displays, but compressor does not run	Compressor relay tripped	Determine reason and take correct action
	Hi-Lo pressure safety switch shut down	Determine type and cause of shutdown and correct it before resetting safety switch.
	Defective contactor or coil	Repair or replace
	Cold room temperature is lower than operation set point	Reset operation temperature set point
	Internal thermal overload tripped	Wait until compressor cools down for reset
	Compressor malfunction	Check compressor motor winding
II- Insufficient supply of the evaporator (s)	Refrigerant charge insufficient	Check the fill level on the sight glass Top up refrigerant
	Drier filter obstructed	Check the filter condition and change the filter/ cartridge if necessary.
	Expansion valve(s) insufficiently open or obstructed.	Check superheating of evaporators Check operation of expansion valves
	Liquid line valve stays open	Check operation of valve, replace if necessary
III-1. Suction pressure too low.	Insufficient refrigerant	Check water tightness of circuit. Top up refrigerant Check for leaks. Repair and add charge
	Surplus oil in the evaporators	Drain the evaporator oil Check absence of oil traps
	Suction filter on compressor(s) clogged	Examine and clean the filter
	Faulty operation of expansion valve(s)	Check operation of expansion valve (s)
	Solenoid valve malfunction (s)	Check solenoid valve(s) opening
	Suction filter(s) blocked	Check filter(s) condition and change the cartridge if necessary
	Non concordance of compressor/ evaporator capacities <ul style="list-style-type: none"> ▪ Evaporators undersized ▪ Compressors too powerful 	Check pressures, temperatures and superheat on evaporators
	Evaporator dirty or iced.	Clean and defrost
	Fan not operate	Check fan motor and circuit control
	Expansion valve underfeeding	Regulate superheat
III-2 Suction pressure too high.	Restart after defrosting	Wait for stabilization
	Compression problem	Check compressor(s) (valves etc.), replace if necessary
	HP too high	See III-4
	Expansion valve(s) too open or jammed open	Adjust superheat Check expansion valve(s) , replace if necessary.
	Excessive load.	Reduce load
	Expansion valve overfeeding	Regulate superheat
III-3 Delivery/ Discharge pressure too low.	Insufficient refrigerant	Check water tightness Top up refrigerant Check for leaks. Repair and add charge.
	Delivery valves broken or leaking	Check state of valves Change faulty parts
	Low suction pressure	See corrective steps for low suction pressure

Problem	Likely Cause	Recommended Action
III-4 Delivery/ Discharge pressure too high	Excess refrigerant	Check and remove excess charge
	Insufficient condenser capacity	Check operation of the condenser
	Presence of non condensable air or gas in HP circuit.	Purge non condensable gases
	Dirty condenser coil	Clean walk-in cooler and walk-in freezer condenser coil
	Fan not running	Check fan motor and its electrical circuit
	System overcharged with refrigerant	Reclaim excess refrigerant
III-5. Suction temperature too low	Liquid in the suction line	Adjust expansion valve(s)
III-6. Suction temperature too high	Superheat too high	Examine and adjust expansion valve(s)
III-7. Temperature of delivery too high	Check loss of pressure in suction pipes	
	Superheat too high on suction	Adjust expansion valve(s)
IV-1. Differential oil pressure too low	Internal bypass	Check state of valves and seals. Replace faulty parts
	Insufficient oil pressure.	Check oil level on compressor(s) crankcase(s). Check that oil filter(s) are clean and change if necessary. Check oil pump operation.
IV-2. Oil level too low	Insufficient oil.	Identify cause of lack of oil(see IV-3). Top up oil
	Oil circuit problem	Check the filter and valves operation. Check operation of the separator. Check operation of the calibrated valve.
	Oil level regulation problem	Check operation of regulator(s). Look for oil traps. Adapt pipes.
IV-3. Oil needs topping up regularly Caution : risk of oil slugging	Leak	Repair and top up oil
	Existence of oil traps	Look for oil traps Adapt pipes
IV-4. Oil level too high Caution : risk of oil slugging	Oil level regulation problem	Check operation of regulator(s) and change if necessary. Check operation of the calibrated valve. Check operation of oil separator
	Oil return from installation	Identify causes of oil accumulation Drain excess oil.
IV-5. Oil foams a lot after stopping	Crankcase heater(s) off	Replace heater(s)
	Liquid in the suction line	Check expansion valve(s) Check water tightness of solenoid valves
V-Large difference between actual cold storage room temperature and set point on control panel	Incorrect room temperature	Re-position sensing point of temperature sensor, reconnect sensor
	Sensor placement, wire too long,	
V-1. Heavy frost builds up on evaporator fins	Too much time between defrost cycles or incomplete defrosts	Manual defrost and adjust defrost cycle
V-2. High temperature alarm	Overload and Open door excessively	Reduce load and door opening
	Bad refrigeration performance	See corrective steps for discharge and suction pressure malfunctions
	Heavy frost build-up on evaporator.	Manual defrost and adjust defrost cycle
V-3. Coil not clearing of frost during defrost cycle.	1.Heater malfunction	1. Check heater operation.
	2.Not enough defrost cycles per day	2.Adjust defrost control
V-4. Ice accumulating in drain pan	Defective heater.	Check or replace
	Drain line plugged.	Clean drain line.



DG Set-Stand by
Power Supply &
Servo Voltage
Stabilizer





Learning Objectives

Installation & Commissioning

- Genset selection
- Installation Check List
- Installation & Commissioning report

Diesel Generator Set General Preventive Maintenance

Principal reasons for preventative maintenance
Proper Preventative Maintenance & General checks
Sample Preventative Maintenance Items LOG SHEET (Sample for use)
Energy Saving Measures for DG Sets DO'S & DON'TS

AMF Panels

Lead Acid Batteries

Servo Controlled Voltage Stabilizer

GENSET SELECTION

To select the right generator under a given, set of circumstances, knowledge of generators and generator performance under various conditions is necessary.

It is also equally necessary to understand load characteristics and to make a load analysis. Beyond that, the effect of the voltage regulation systems plays an important role.

However, a really detailed analysis is usually not required and it is best to err on the side of selecting a slightly larger generator. The reason is that additional uses are invariably found for the output of a generator, once it is installed. These are usually not predictable. By having a margin available it is possible to power some loads which may have been overlooked in the beginning, or which may be added after the installation of the generator.

RATINGS

The rating of an alternator is expressed either in kilowatt (kW) or kVA.

The relation between kW and kVA for a 3 phase power

kW = kVA x Power Factor

$$= \frac{3 \times V \times I \times \text{Power Factor}}{1000}$$

where

V = Line voltage

A = Line current

If alternator or AC Generator is Star Connected as usually the case, then the Line Voltage is $\sqrt{3}$ times the phase voltage. ($V_L = \sqrt{3}V_{PH}$)

Hence the 3 phase power output for alternator is kW = kVA x Power Factor

$$= \frac{\sqrt{3} \times V \times I \times \text{Power Factor}}{1000}$$

For a single phase alternator

kW = kVA x Power Factor

$$KW = \frac{V \times I \times \text{Power Factor}}{1000}$$

Normally, a generator is designed for a power factor of 0.8.

CAPACITY

The most important factor in selecting a genset is of course its size and capacity. A careful-study should be made to determine exactly to what end use the genset is being put to, and the total wattage.

It is advisable to take a long term view and select a slightly larger generator, since it often become necessary to add more equipment to the load in future years. Moreover, by having a margin available, it is possible to power loads, which may have been overlooked in the beginning.

ENVIRONMENT

This plays an important role and determines the type of enclosure and the degree of protection for the generator which in turn affects the rating that can be obtained for a given machine. For the set to operate in a chemical and corrosive atmosphere special treatment for winding and other parts should be provided and special materials are required while manufacturing the generating set. While selecting a genset, information regarding additional demand should be obtained to avoid overloading the generating set. At the same time, unnecessarily larger capacity genset should not be selected, as this will result in running the engine on lower loads. The average load factor on the engine should be around 80% of rated full load. This will ensure both optimum fuel consumption and long life of the engine.

Installing the Genset.....Some important Points...

- The Diesel Generator (DG set) should be installed on a solid concrete foundation having at least six reinforced foundation bolts.
- Keep at least 1 meter away from the surrounding walls and other equipments to prevent fire hazards and provide adequate ventilation.
- The DG set should operate only on the levelled surface. Keeping set on unlevelled surface may result fuel spillage and oil pump may not get the Lubricating oil, causing seizer of crank shaft bearings.
- Never run the DG set in close area, the exhaust gases contains poisonous carbon mono-oxide. Ensure the exhaust fumes are released in the open area at a sufficient height outside the building where WIC/F is installed.
- Keep DG set in locked condition so that no unwanted person may access the DG set.
- The DG set should be earthed properly. Never run the set without proper earthing.
- Always use lubricating oil recommended by the manufacturer depending upon the ambient temperature. For the selection of the lubricating oil grade, anticipated lowest temperature at the time of start should be considered in the winter season and highest temperature of the day during summer season.

Location

Dust and Fumes are the greatest danger to generating set as they could lead to clogging of cooling and air system which may affect Genset performance.

- If Genset is to be installed in Free field condition, please ensure dust free location and clear space of 2 times the height of Genset.
- If Genset is to be installed in the room, please ensure proper cross ventilation, clear space of minimum 3 meters from all sides.

Layout

- Allow easy accessibility to Genset for easy operation and maintenance.
- Locate the Genset considering the prevailing wind direction.
- Genset installation should be as close as possible to the load.

Noise

- There should be sufficient space around the Genset to avoid resonance and echo effect which contributes to abnormal sound from Genset.
- The space should be open without any obstacles.

Ventilation

- Cross ventilation and free flow of cool, clean and fresh air.
- The space should be open without any obstacles.
- For room installations, supply of fresh air and removal of hot air should be done through forced ventilation with suitable air ducts.
- Maximum allowed temperature rise above ambient in Genset Enclosure at air intake of engine is 7°C–9°C.

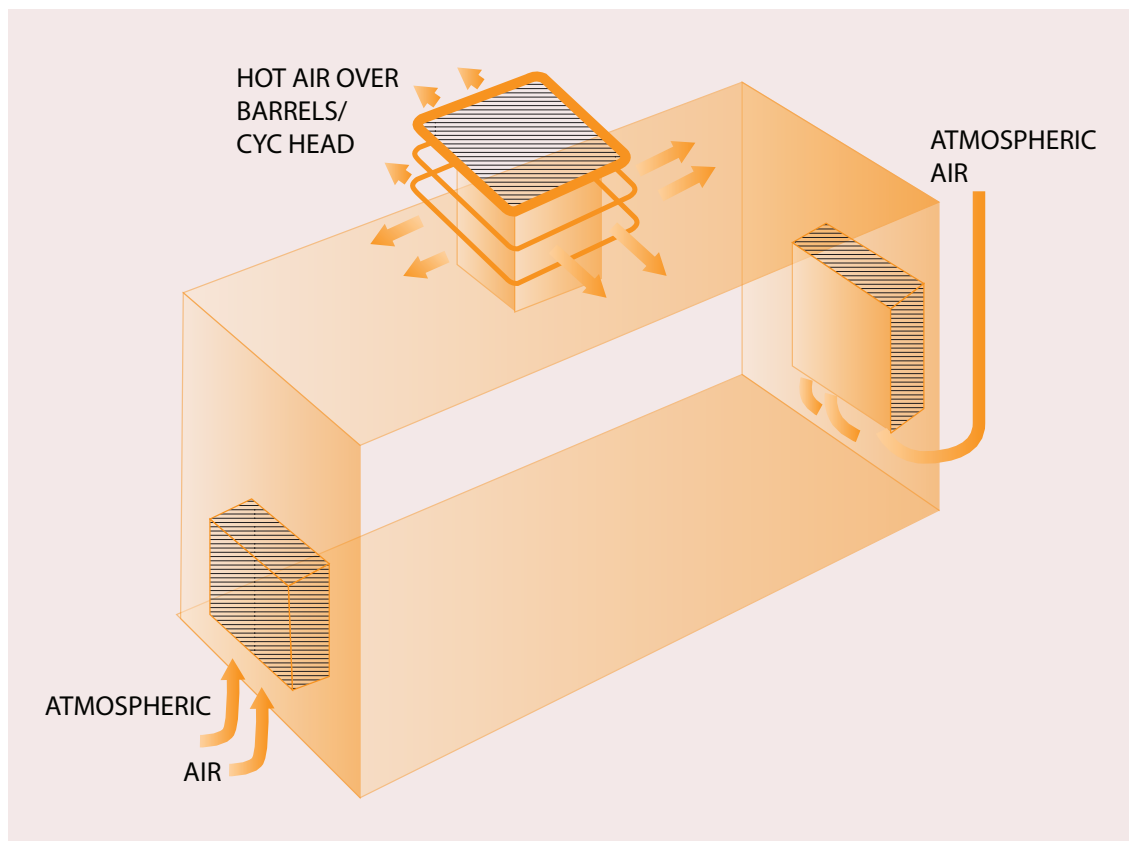

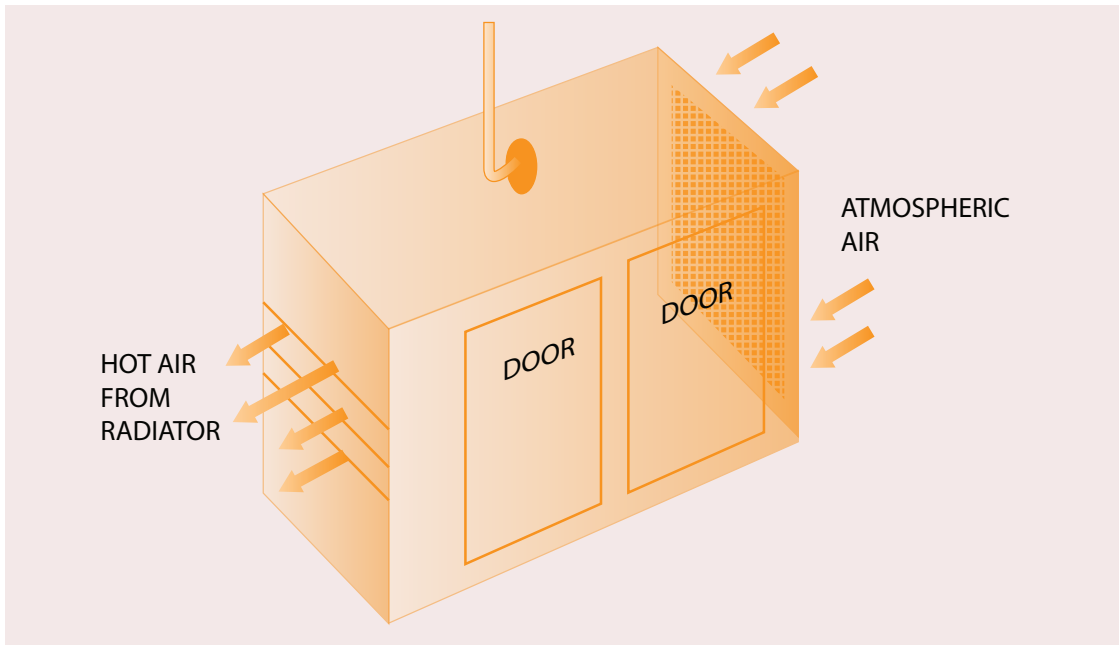

Foundation

Proper foundation for generator set is required, along with raised platform. It should have canopy/ protection, to protect from elements.

Foundation is one of the important factors affecting the successful operation and life of a generating set. Improper foundation may result in alignment and vibration problems which may subsequently lead to pre-mature failure of Genset Components and Safety.

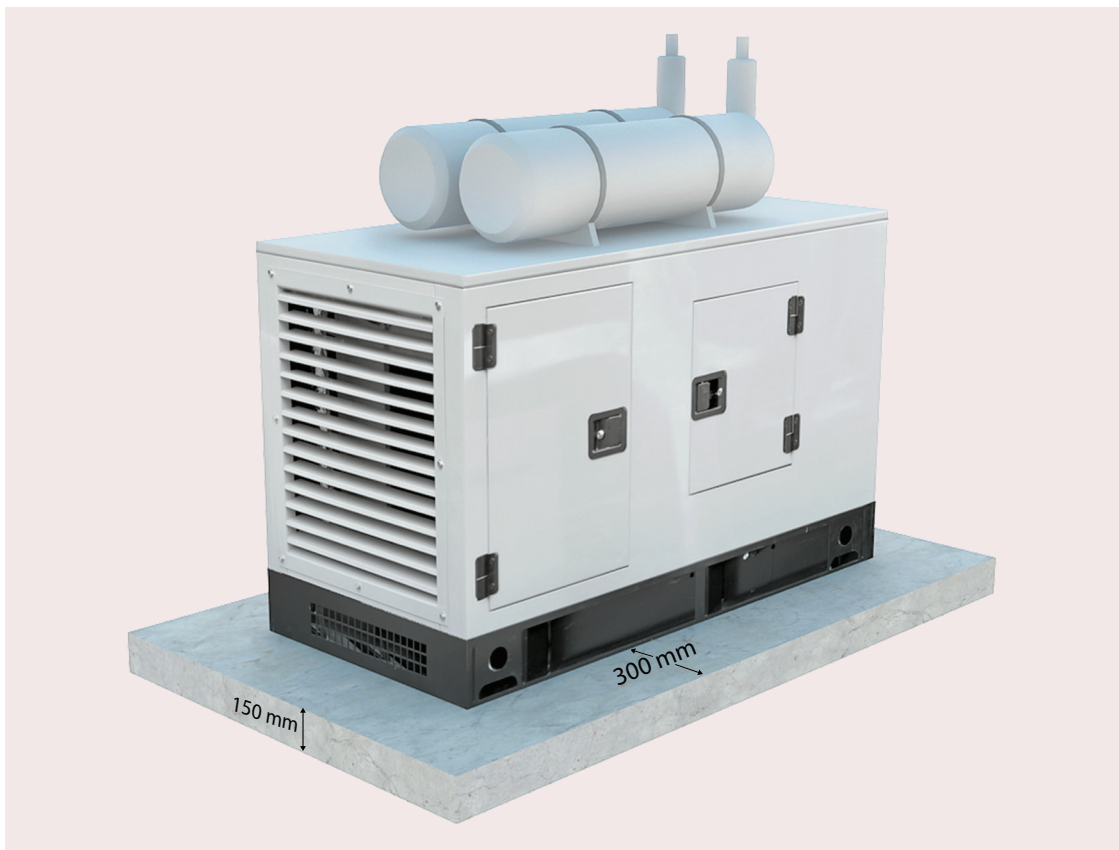

Exhaust System

Genset Exhaust system directs the hot flue gases into the atmosphere harmlessly.

The exhaust should be in the direction of prevailing wind.

Ensure that site allows smoke genset smoke exhaust through pipe.

Electrical System Earthing

Any leakages in current will be earthed through the shortest route in the link.

Genset should be connected to earth in accordance with local regulations.

The generating set and all associated equipment must be earthed before the set is put into operation.

4 numbers of earth pits are required as per Indian Electricity rules / local electricity regulations.

- 2 earthing pits for Genset / control panel body
- 2 earthing pits for neutral.

Resistance between 2 earth pits should not be more than 5 ohms.

Typical Earth Pit diagram is as shown in figure.

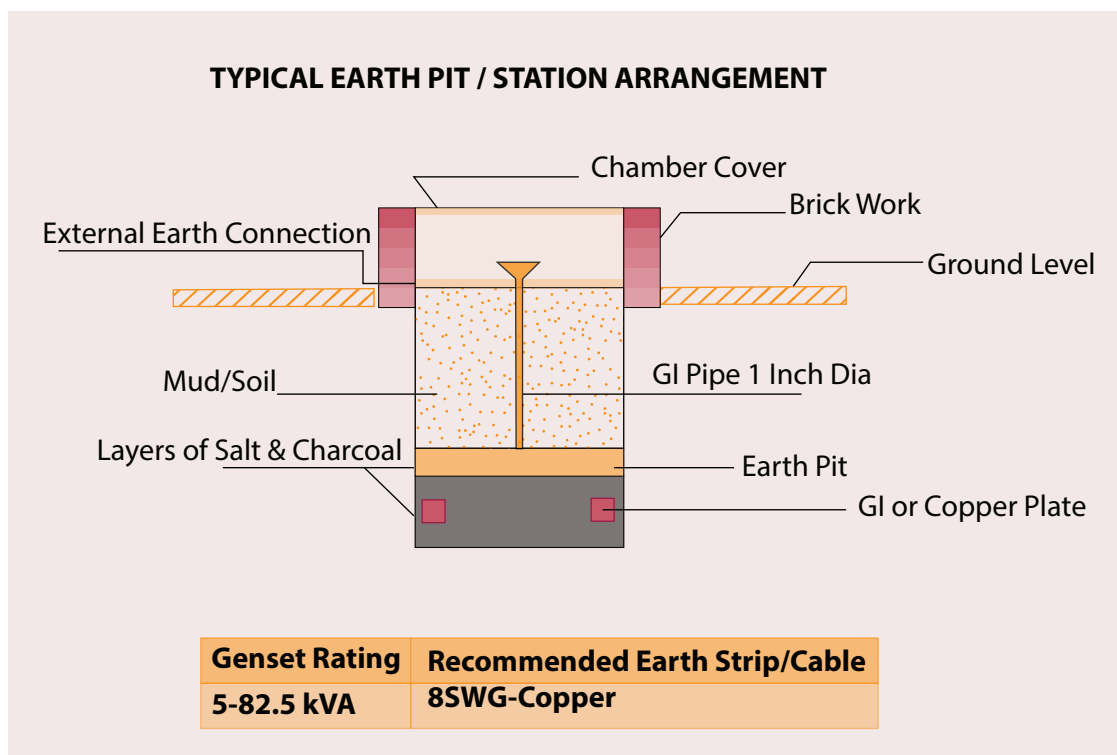

Regarding KVA rating /Dimensions/Weight....

The Kirloskar model is given for reference purpose only. The dimension & weight varies model to model for various manufacturers.

DG SET INSTALLATION CHECK LIST

Sr.No.	Items	Status
Location Related		
1	Is the DG set is at sufficient height to prevent water entry in rainy season?	Yes / No
2	Is space surrounding DG set sufficient to allow maintenance work?	Yes / No
3	Is the space around is leveled without pits, slopes & other physical obstruction (as otherwise it is a safety hazard to persons attending)	Yes / No
4	Whether the DG room has adequate cross ventilation?	Yes / No
5	Whether the hot air from radiator moves out without obstruction?	Yes / No
6	Is care taken that the rain water falling from adjoining building do not fall on the DG set?	Yes / No
7	Is exhaust directed away from likely to human injury or damage to other equipment or inlet for acoustic?	Yes / No
Foundation & Platform Related		
8	Is the foundation leveled properly so that there is no gap between base frame and platform surface of the foundation?	Yes / No
9	Is the area of the platform adequate to provide seating for the entire set?	Yes / No
Product Intactness Related		
10	Is the base frame without damage and waviness at the bottom?	Yes / No
11	Is the enclosure dented or damaged during handling, leading to rusting?	Yes / No
12	Is the door alignment OK?	Yes / No
13	Is the lock for enclosure functioning properly?	Yes / No
14	Whether bolts holding engine, alternator, control panel, silencer, exhaust fan, fuel tank and of acoustic enclosure are tight?	Yes / No
15	Whether control panel components mounting tight and not loose?	Yes / No
16	Whether battery has any physical damage?	Yes / No
17	Whether any wire hanging loose or connection loose?	Yes / No
18	Whether all fuel connections and drain plug are tight?	Yes / No
19	Whether AVMs are positioned & not displaced?	Yes / No
Earthing & Cabling		
20	Whether enclosure earthed?	Yes / No
21	Whether neutral earthed?	Yes / No
22	Whether alternator body earthed?	Yes / No
23	Is cable of mains & load exerting pressure on terminals?	Yes / No
24	Whether connections to mains, load & alternator is with proper phase sequence?	Yes / No
Leakage Related		
25	Is the lube oil level at the accepted level?	Yes / No
26	Is the coolant level in the radiator at the accepted level?	Yes / No
27	Whether diesel is available at the required level of the fuel tank?	Yes / No
28	Whether any leakage of fuel, lube oil and coolant observed at drain plug, banjo point crimping or in the pipes or at the neck of the tank or in tank joints?	Yes / No
Verified		
Signature of technical staff		
Signature & seal of Facility In charge		Signature & seal of Installer

DG SET INSTALLATION & COMMISSIONING REPORT

Name & address of consignee					
Type of Service		Erection	Commissioning	Warranty	Courtesy
	Rating	Make	Model	Serial No	
Engine					
Alternator					
AMF Panel					
Work done & Recommendation					
Canopy surrounding area details: Distance from obstacles-mtr/mm	A) Engine Side.....	C) Fuel Pump side.....	E) Above roof.....		
	B) Alternator side....	D) Battery Starter side.....			
Performance check					
Water Temp		Voltage		Alignment check	
Lube oil grade		Amps		FACE	
Lube oil temperature		P.F.		AXIAL	
Lube oil pressure		KW		+ +	
RPM		Hz			
Battery rating		Operation	Manual		
			Auto		
		Earthing	Done		
			Resistance value		
			Not done		
Load Details		Canopy Model & Serial No.			
	Size	Rating	Nature of Load	Ventilation	OK NOT OK
WIC				Noise Level	OK NOT OK
WIF				Temperature	Ambient..... Inside.....
Other...specify				Vibration	Yes No
				Mounting	Rigid AVMs
		Cooling Type/Make/Rating			
				Exhaust	a)Dia
					b)Support Yes No
					c)Rain Protection Yes No
				Cable Size	
Detail of Engine & Alternator after sales & Service given to consignee				Yes	No
Operation & Maintenance Practices of D.G. set demonstrated to consignee/technical staff.				Yes	No

General Preventative Maintenance

Diesel engines comprise the vast majority of prime movers for standby power generators because of their reliability, durability and performance under load. In standby power applications, diesel generators can start and assume full-rated load in less than 10 seconds, and they typically can go 30,000 hours or more between major overhauls.

Scheduled planned maintenance programmes are the most effective process for ensuring a generator system is maintained fully operational and ready to start and take its load when primary power is off-line for any planned or unplanned reason.

This information sheet details the routine preventative maintenance to ensure high reliability.

Diesel Generator Set General Preventive Maintenance...

- Principal reasons for preventative maintenance
- Proper Preventative Maintenance & General checks
- Sample Preventative Maintenance Items
- LOG SHEET (Sample for use)
- Energy Saving Measures for DG Sets
- DO'S & DON'TS

Preventive maintenance

Because of the durability of diesel engines, most maintenance is preventive in nature. Preventive diesel engine maintenance consists of the following operations:

- General inspection
- Lubrication service
- Cooling system service
- Fuel system service
- Servicing and testing starting batteries
- Regular engine exercise

It is generally a good idea to establish and adhere to a schedule of maintenance and service based on the specific power application and the severity of the environment. For example, if the generator set will be used frequently or subjected to extreme operating conditions, the recommended service intervals should be reduced accordingly. Some of the factors that can affect the maintenance schedule include:

- Using the diesel generator set for continuous duty (prime power)
- Extreme ambient temperatures
- Exposure to weather
- Exposure to salt water
- Exposure to dust, sand or other airborne contaminants

If the generator set will be subjected to some or all of these extreme operating conditions, it is best to develop an appropriate maintenance schedule. The best way to keep track of maintenance intervals are to use the running time meter on the generator set to keep an accurate log of all service performed. This log will also be important for warranty support.

Principal reasons for preventative maintenance

Reliability - Diesel power systems provide standby power to many critical applications.

Performance - Preventative maintenance greatly reduces the risk that an internal or ancillary component malfunction will cause the generator to produce insufficient power. By identifying problems generator power is needed, users can schedule backup power while the primary standby unit is being serviced.

Safety - Component failure presents risks both to personnel on site and to those relying on the output of the generator set. Preventative maintenance Programmes are designed to detect normal life-cycle deterioration of components within the system and replace those components before they fail.

Economics - Early detection of internal or external problems enables the correction of those problems before a failure occurs. This yield significant savings through shorter down times and lower repair costs. It can prevent larger economic losses that would occur if a standby system failed to come online when needed. (Continued over)

Items need to cover under generator preventative maintenance programmes are:

Fuel System - Diesel fuel degrades over time and susceptible to contamination. The fuel, pipes, filters and injection equipment are key items to check in any preventative maintenance programmes.

Batteries - Inadequate battery maintenance and neglecting to monitor the condition of the battery charger and starter motor are among the most common reasons generator sets fail.

Coolant - Leaking coolant or a poor coolant mixture can lead to overheating of the system.



Filters - Filters are used to avoid contamination of a system that can lead to failure and reduced performance. PM programmes will ensure air. Fuel and oil filters are inspected and changed when required.

Proper Preventative Maintenance & General checks should include following:

1. Preventive maintenance and to fill up preventive check up schedule for each machine.
2. Replacement of following parts (Every 300 Hrs. of engine operation / 6 months whichever is earlier) (i) Fuel Filter (ii) Lubricating Oil Filter (iii)By pass filter (iv) Coolant (v) Engine oil (vi) Air Filters.
3. Checking and servicing of engine for smooth running, its unusual sound and color of smoke from exhaust and set it right in case of deviations.
4. Checking and repairing the leakage of fuel, lubricating oil and coolant.
5. Cleaning and changing of Air filters. (as per requirement)
6. Setting of Valves tappets whenever required.
7. Checking and repairing of Accessories drive, Turbo Charger and crankshaft endplay (whenever required).
8. Checking of alignment and alignment of Engine and Alternator (as per requirement)
9. Checking of throttle control & its setting.
10. Checking of instrument on instrument panel including replacement as and when required.
11. Checking of rotating diodes assembly in brushless alternator including replacement as and when required.
12. Checking of wiring system and repairing / replacement as and when required.
13. Repair and Maintenance of Relays including contractors in control panel.
14. Checking of battery terminal and de-sulphation.
15. Re-level generator (when necessary)
16. Verify voltage and frequency output
17. Adjust fuel regulator & Adjust engine speed if necessary.
18. Paint gas pipe to prevent rusting
19. Diagnosis of faults in engine and Alternator and its rectification.
20. AMF panel functionality & operation.

UP KEEP

1. As a daily routine, clean the DG Set with dry cloth.
2. Keep the door of the DG Set closed.
3. Don't fill the fuel without strainer.
4. Maintain log book for DG set.

WATCH KEEP

1. Verify battery charge, lube oil level, coolant level & fuel level in the daily routine checks.
2. Regularly check all the connections of air, oil, coolant, fuel and exhaust for leaks. Report if abnormal.
3. Observe loosening of parts, nuts & bolts. Report if abnormal.
4. Observe for unusual sound of set. Report if abnormal.

Chart - Sample Preventative Maintenance Items for a Diesel Generator Set

Diesel Generator Set Key Maintenance Items		Method of Checking and Action to Take					Frequency of Check
		Visual	Record	Change	Drain	Test	
1	Coolant heater and level	X	X				Daily
2	Check and record oil and fuel level	X	X				Daily
3	Examine charge-air piping	X					Daily
4	Drain water from tank & filter		X		X		Weekly
5	Check air cleaner	X					Weekly
6	Check battery charger	X					Weekly
7	Check coolant concentration		X		X		Monthly
8	Exhaust water-trap	X			X		Monthly
9	Check drive belt tension	X					Monthly
10	Check starting batteries	X	X			X	Monthly
11	Change fuel, oil and air filters		X	X			6 Months
12	Clean crankcase breather				X		6 Months
13	Examine radiators hoses	X					6 Months
14	Flush and clean cooling system				X		Annually

LOG SHEET (Sample for use)

The user is requested to maintain a separate log book registering the following mentioned parameters in the table.

Following tables are meant for providing a reference to you.

Date						
Daily use in hrs.						
Hour meter reading						
Cooling Water Temp (°C)						
Lub. Oil	Pressure(Kg/cm ²)					
	Temp (°C)					
Fuel added (liters.)						
Lub.Oil added (ml)						
Engine (rpm)						
Current (Amp) 3-phase/1-phase						
Voltage (Volts)3-phase/1-phase						
Frequency(Hz)						
PF & kW if provided						
kWH meter reading if provided						
Remarks - Record events of maintenance / repairs						



Energy Saving Measures for DG Sets

- a. Ensure steady load conditions on the DG set, and provide cold, dust free air at intake (use of air washers for large sets, in case of dry, hot weather, can be considered).
- b. Improve air filtration.
- c. Ensure fuel oil storage, handling and preparation as per manufacturer's guidelines/ oil company data.
- d. Consider fuel oil additives in case they benefit fuel oil properties for DG set usage.
- e. Calibrate fuel injection pumps frequently.
- f. Ensure compliance with maintenance checklist.
- g. Ensure steady load conditions, avoiding fluctuations, imbalance in phases, harmonic loads.
- h. Regular field trials are necessary to monitor DG set performance, and maintenance planning as per requirements.

DO'S & DON'TS

Do's

- Ensure that keys for the locks are in proper custody.
- Use proper & appropriate place for storage of DG set, Spares and associated items.
- Understand information provided in DG operation & maintenance literature and as conveyed during training & follow them.
- Ensure minimum 1-meter clear distance between DG set & all surrounding structures. Remove obstacles if any for easy access to DG set.
- Ensure free flow of fresh air to inlet provided on DG set and hot air from radiator to move out to atmosphere without restriction / reflection.
- As a daily routine, clean the DG set with dry cloth.
- Include verification of battery charge, lube oil level, fuel level & water level in the daily routine checks.
- Regularly check all connections of Air, Oil, Water, Exhaust & Diesel for leaks.
- Release start push bottom when speed picks up to prevent damage to self starter.
- Allow sufficient gap between successive starts to prevent draining of battery.
- While operation in manual mode, run for a while on No-load before loading. Disconnect the load first & run for a while on No-load before stopping the DG Set.
- Be alert for any unusual sound of DG Set and report without delay.
- Maintain DG Run log book, Fuel log book & Visit Register.
- Ensure maintenance checks are carried out in specified time as suggested in DG set user Manual.

Don'ts

- Don't allow DG set to run in inclined position.
- Don't allow unauthorized person/s to meddle with DG sets.
- Don't commission the DG set in the absence of authorized service person/s.
- Don't fill the fuel without strainer.
- Don't allow operation of the DG set without proper Earthing.
- Don't fill the fuel when set is running.
- Don't bring the naked flame near the battery when it is being charged.
- Don't press start button when the set is running.
- Don't disconnect the battery when the set is running.
- Don't operate the DG with Engine Oil below 'min' mark on the Oil dip stick.
- Don't start the DG set when there is any fault indication.
- Don't run the DG set without Maintenance checks as in user manual.
- Don't stop the set on LOAD.
- Don't open the Radiator cap when the set is running / hot condition.
- Do not over load the set.

Auto Mains Failure Panel

The panel generally consisting of: -

1. 4 x 20 character back lit LCD on front fascia for showing various parameters of mains & DG viz. 3 ph voltage, 3 ph current, frequency, KWH of mains, KWH generated by DG, month wise energy register, PF of all 3 phases, DG running hours, DG battery voltage, DG speed etc.
2. 2Nos. of 4 pole MCCB (with adjustable current setting). This rating of MCCB is as per the KVA rating of DG Set.
3. 2 Nos. of 4 pole contactor for a) mains b) DG set
 - a. The Rating of Contactors shall be derived from KVA rating and the minimum voltage. Both the contactors shall be electrically interlocked with contactor coil.
 - b. Potential free contacts for extension of alarms- (6 Nos.) viz. lack of fuel, LLOP, Mains Fail, Engine Fail to start, Canopy door opening, high cylinder / Water temp.
 - c. Microprocessor based Automatic Mains Failure Controller (suitable for 12VDC),

Operational Requirement

1. AC and DC wiring shall be separated distinctly.
2. Connections of control wiring shall be done with connector strips and ferrules for identification on both ends.
3. 1No. Multifunctional meter to indicate Voltage, Current, PF, Frequency & kWh of DG Set.
4. Push button for stop, reset, and acknowledge.
5. Recess type hooter.
6. Audiovisual indication for LLOP, HCT / HWT, over speed, Lack of fuel.
7. RYB LED indication for indicating Mains / DG Set Supply - 2 sets.
8. DC Ammeter, DC Voltmeter of with selector switch for trickle charging through battery charger and battery charging unit
9. Selector switches for Auto /Manual operation.
10. Battery Charger: Automatic trickle battery charger of SCR or SMPS type to charge the starting battery of DG set. This charging shall be done through main supply for which a suitable incomer shall be provided in the panel with suitable range of ammeter and voltmeter on the DC side with protective fuses.

The following parameters are required to be monitored by AMF panel:-

- a. Line - Neutral Voltage of all three phases of mains and DG
- b. Load current for all three phases
- c. DG Run hours
- d. DG battery voltage
- e. DG Speed
- f. Frequency
- g. Mains KWH
- h. DG KWH

In case of abnormal conditions, the following alarms are needed to be actuated by AMF panel:-

1. LLOP (Low Lube Oil Pressure)
2. DG fails to ON
3. DG battery low
4. DG fuel low (for stopping of engine)
5. DG fail to stop
6. Under speed / Over speed
7. Start/Stop fault
8. Engine Temperature high
9. Alternator fault
10. Mains ok / mains faulty
11. Overload
12. Over / under voltage
13. Over / Under frequency
14. Canopy temperature high
15. Low water level (for water cooled sets)

Safety Control Trip.

1. Low lubricating oil pressure.
2. High cylinder / water temp.
3. Lack of fuel.
4. Alternator Fault
5. Over speed
6. Fire Alarm (if provided)

Preventive Maintenance in AMF Panel

The following should be checked during preventive maintenance:

- Checking all connection & relays
- Cleaning of all parts
- Adjustments of all relays & parts
- Checking all calibration of AMF controller System, Software & program etc.
- Rectification of any kind of problem.
- Check normal operation of the system.
- Examination & rectification of fault codes.

Lead Acid Battery.....



Note: Always refer to the instructions included with the battery for proper procedures and care.

Caution: Always wear the necessary protective clothing when working with a battery, especially gloves and safety glasses!

BATTERY CHARGING PROCEDURE

A. Battery charging procedure

If dry battery is supplied along with the DG set then initial charging of the battery is required. Please get initial charging of the battery done from an authorized service dealer of the battery manufacturer. The initial charging process is of 72 hours. Specify gravity of acid inside the battery should be 1.23 to 1.28 kg/liter.

NOTE

Undercharging not only reduces the battery capacity in day to day work activities, but causes abnormal sulfation leading to further reduction of capacity and early cell failure.

Undercharging can result from improper sizing of the battery charger, a malfunctioning charger, over discharging of battery, bad battery cables, connectors, and improper operator setting of non-automatic chargers. Overcharging will not only create unnecessary utility expense, but will cause high temperatures and over gassing resulting in premature cell failure.

Overcharging can result from improper sizing of the battery, charger, and improper operator setting of non-automatic chargers.

B. Method to use charged battery

If charged battery has been provided along with the DG set, and the DG set is not in use then ensure that at positive terminal battery lead is not connected. It should be connected at the time of the commissioning of the DG set.

Charged battery may be used for commissioning of DG set within 15-20 days; else recharging of charged battery is required.

Always connect the battery with the proper battery charger. The battery should be connected to the battery charger, which is connected with 230V AC supply.

The Battery charger is provided with an AMF Panel (Auto Mains Failure Panel) under the standard scope of supply. 230V AC supply is essential for battery charger operation.

NOTE

Normally unless & until specified, the battery charger is not supplied with a standard manual Panel. So, if it is so, then it is suggested that the DG set must run once a day for 15-20 minutes so that Battery is charged by engine dynamo/ charging alternator.

C. Precaution to be taken during handling of battery.

- Never smoke or have open flame or spark near a battery. Flame, Candle and matchbox should not be used near charged battery.
- Always wear personal safety wear when inspecting, servicing or working near batteries. Use hand gloves while handling the charged battery.
- Always maintain correct electrolyte levels as specified. Electrolyte level should be below the neck.
- Always maintain batteries in clean and dry condition. Do not charge the battery at a wet a place.
- Always insure no metal objects come into contact with the battery. Never put tools etc.on the battery.
- Always add distilled or approved water only. If spill-overs occur, contact battery expert
- Discharge batteries no more than 80% of their rated capacity. Ideal discharge/ charge parameters are 6 hours use, 8 hours' charge and 4 hours cool-down prior to use.
- Never place a hot battery on-charge or in operation. If battery is hot (+115°F), contact battery expert for inspection.
- Always perform and record electrolyte and cell voltage readings on a minimum quarterly basis on each 75 discharge cycles.
- Remove or open all covers from batteries during charge, insure adequate ventilation exists in all areas where batteries are being charged.
- Always switch off the charger first before disconnecting the battery from the DG set.

The normal failure modes of lead - acid batteries

Sulphation in cells

Buckling of plates:

Shedding of active materials:

Container trouble:

Loss of capacity:

Internal short circuit:

Reversal of plates:

Earth / surface leakage in battery:

Lead Acid Battery Maintenance.....

Weak or undercharged starting batteries are the most common cause of standby power system failures. Even when kept fully charged and maintained, lead-acid starting batteries are subject to deterioration over time and must be periodically replaced when they no longer hold a proper charge. Only a regular schedule of inspection and testing under load can prevent generator starting problems.

Periodic testing of the battery with maintenance records can be useful for early detection of internal irregularities. Early detection and corrective action is necessary for battery longevity. Recommended procedure is to take specific gravity readings, and on charge voltage readings after equalize charge. This should be done quarterly with results recorded and compared to most previous readings. If a problem is suspected, these measurements and comparisons should be done more frequently. Monthly or weekly would be more appropriate until satisfied that an accurate indication of the health of the battery has been determined.

Testing batteries:

Merely checking the output voltage of the batteries is not indicative of their ability to deliver adequate starting power. As batteries age, their internal resistance to current flow goes up, and the only accurate measure of terminal voltage must be done under load.

Cleaning batteries:

Keep the batteries clean by wiping them with a damp cloth whenever dirt appears excessive. If corrosion is present around the terminals, remove the battery cables and wash the terminals with a solution of baking soda and water (1/4-pound baking soda to one quart of water). Be careful to prevent the solution from entering the battery cells, and flush the batteries with clean water when done. After replacing the connections, coat the terminals with a light application of petroleum jelly.

Checking specific gravity:

Use a battery hydrometer to check the specific gravity of the electrolyte in each battery cell. A fully charged battery will have a specific gravity of 1.260. Charge the battery if the specific gravity reading is below 1.215.

Checking electrolyte level:

Check the level of the electrolyte in the batteries at least every 200 hours of operation. If low, fill the battery cells to the bottom of the filler neck with distilled water.

Monthly Maintenance:

The following maintenance will be necessary to gain optimum performance and life from your batteries:

1. Keep idle batteries charged.
2. Charge properly.
3. Do not over discharge.
4. Maintain proper electrolyte level.
5. Keep clean and dry.
6. Perform periodic testing.
7. Keep battery records and analyze data.
8. Repair immediately when needed.

If your machine is charging the battery correctly, very little maintenance is needed. However, it is important to check the battery monthly to get the most life out of it.

Keep the battery charged to 100%, recharging when the starter sounds weak, or the battery hasn't been used in more than two weeks. Other than that, follow this simple check list

Every month:

- Check the electrolyte (acid) level (for standard type batteries). If low, fill with distilled water (never re-fill with electrolyte)
- Clean the top free of grime and corrosion
- Check cables, clamps, and housing for fraying, obvious damage, loose connections or burned contact areas.
- Inspect cable leads and connector for, loose connections or
- Keep the terminals and connectors clean
- Make sure the exhaust tube is free of kinks and clogs (standard type batteries)
- Finish up by testing the battery with either a battery tester or voltmeter. To extend the service life of your battery, make monthly battery maintenance part of your routine.
- Take specific gravity reading on every cell - AFTER CHARGE!

DO'S & DON'TS

Do's

1. Do wear safety glasses while working on or around your battery.
2. Do keep caps on all cells while operating, charging, and washing.
3. Do keep water level above splash guard at all times.
4. Do add water, if necessary, after the battery is fully charged.
5. Do check that charger is operating after hook-up to the battery.
6. Do use proper equipment and methods for changing.
7. Do wash hands after working on or around your battery.
8. Do use distilled or deionized water.
9. Do use charger for equalize option at least once per month, but no more than once per week.
10. Do use automatic start/stop charge control (s) to prevent overcharging and undercharging.

Don'ts

1. Don't smoke in the charging area.
2. Don't disconnect or connect battery to charger while charger is operating.
3. Don't overfill battery cells.
4. Don't discharge more than 80% or below specific gravity of 1.160.
5. Don't allow discharged battery to sit long periods before recharging.
6. Don't leave battery cover in closed position during recharge.

Notes

.....

.....

.....

.....

.....

.....

.....

.....

.....

.....

SERVO CONTROLLED VOLTAGE STABILIZER

The problem of fluctuations in voltage affects the life and performance of all types of electrical appliances. The voltage requirements of different electrical appliances, however, vary to a great extent. The sophisticated medical electronic instruments like spectrophotometers, PH meters, Counters, Recorders, Gas Chromatographs, X-ray Plants are all affected by high Mains voltage, whereas the Refrigerators, Deep Freezers, B.O.D. Incubators, WIC/WIF and other compressors are affected by low Mains voltage. The stabilizer should be capable of working on extremely low loads at high efficiency, without producing any distortion. The modern Servo Stabilizer, in addition, has built – in Thermal overhead protection to safe ground them against accidental overload and short circuit.

The servo stabilizer has four basic components:

- 1 Stepless Variable Toroidally-wound (SVT) Auto -Transformer
- 2 Reversible, instantaneous start/stop Step-Synchronous Motor
- 3 Double wound step up Transformer
- 4 Solid State Sensing Circuits

The basic diagram for Servo Controlled Voltage Stabiliser is as given below.

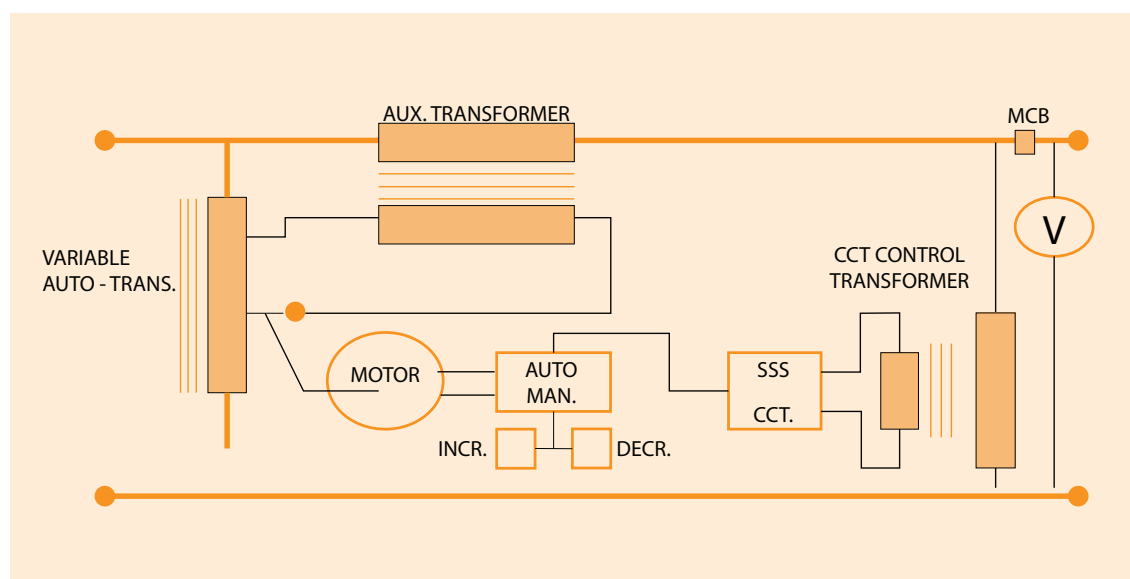

INSPECTION/INSTALLATION PROCEDURE

1) INSPECTION:

The stabilizer should be carefully examined for any physical damage during transit. The equipment generally rugged & manufactured to withstand normal shocks and vibrations during transit. Yet it is desirable to ensure that there is no physical damage.

2) UNPACKING

Unpack the stabilizer carefully taking care that is not damaged while opening the wooden case/crate. Check for any external damage. In case any damage report to the provider in writing within a stipulated time period.

3) INSTALLATION:

The stabilizer should be installed in a clean dry atmosphere, fairly cool and well-ventilated place. It should be kept above the floor level as far as possible. The chassis of the stabilizer must be connected to the 'earth' of the supply. The unit should be installed at a place protected from rain and water.

The stabilizer should be installed. Please follow the installation & troubleshooting procedure before connecting the load.

4) CAUTION:

Care must be taken to connect the input & output supply leads at the right place. They should not get inter changed. Connect the solid neutral point to the input supply terminal & not the ground wire otherwise it would result in malfunctioning of the unit.

5) START UP

Before switching ON, check the following:

- Panel controls for their mechanical mounting.
- Installation resistance between stabilizers. Ground (Chassis) and each phase. It should be more than 5 M Ohms.
- Mains earth and its connection to stabilizer chassis.
- The voltage between supply neutral and mains earth should be less than 5 V.

Instruction normal operation of Servo Controlled Voltage Stabiliser. (SCVS)

The following order of sequence should be followed:

- Check input & output connections are proper.
- Connect the load to the output terminals. The load current should not exceed the ratings of the unit, with due considerations for power factor of the load.
- Keep the auto/manual switch in 'AUTO' mode.
- Switch 'ON' the mains input supply voltage.
- Switch 'ON' the input MCB or MCCB.
- With the help of input/output selector switch, monitor the input & output supply voltage.
- The output voltage of the unit is factory set at required value.
- To switch 'OFF' the load, switch of the MCB/MCCB provided.

MANUAL OPERATION:

In the unlikely event of control circuit failure, the SCVS can be used manually to correct output voltage.

1. Keep the AUTO/MANUAL switch in 'MANUAL' position.
2. With the 'INPUT/OUTPUT' selector switch, kept in output mode, monitor the output voltage.
3. Depending on whether the output voltage is more or less than required value, Press momentarily the 'INC/DEC' switch as needed.
4. In the 'INC MODE' the output voltage will be increased while in 'DEC-MODE', the Output voltage will decrease.
5. Repeat the above sequence when the input supplies changes. However, it is recommended the stabilizer should not be used in MANUAL MODE for longer duration.

OPERATION IN AUTO MODE (WITH LOAD)

1. Keep incoming supply off. Check insulation resistance of output cable as well as load (more than 5M Ohms).
2. Locate neutral of the load properly and connect it to stabilizer output terminals. Ensure proper terminations. Input and output terminals should be tightened properly so that there is no heating of terminals. Now proceed as under.
3. Keep LOAD ON switch in ON position and load should be kept OFF. Switch incoming supply ON.
4. Check input / output phase voltages.
5. Switch the Load ON.
6. Check load current in each phase.
7. Check phase in neutral voltage at input and output.
8. Check supply neutral to earth voltage. It should be within 5V.
9. Leave the stabilizer on load for about 15 minutes.
10. Switch off the supply and check the input and output terminals of the stabilizer. If there is any overheating of terminals, check the terminals again and lighten the input / Output terminals further. Repeat the above procedure till there is no further overheating of terminals.

The Servo stabilizer is now installed and ready for use.

MAINTENANCE

- The SERVO CONTROLLED VOLTAGE STABILISER doesn't require any regular maintenance. However carbon brush of the variac should be checked occasionally. If required it should be replaced by a fresh one. Most of the manufacturer used to give it as spare in moveable arm of the variable transformer
- In case, carbon gets deposited on the conducting surface of the variac it should be cleaned up after disconnecting the main input supply

- If the unit is working well in the MANUAL mode i.e. the O/P voltage can be decreased/ increased by pressing the DECREASE/INCREASE push switches.
- If it does not maintain the O/P voltage constant at the desired level in AUTO mode then please check the electronic - control circuit P.C.B & replace if required.

Trouble shooting Part

1) Output Voltage Unbalanced

- a. Check Input Supply whether all the 3 phases are present. If so;
- b. Carbon brush may have worn out or broken.
- c. Snapped or loose. Connection on Input/output. Correct the same.

2) Output Voltage fluctuating continuously

- a. Adjust output Pot clockwise on the Servo Control Card till fluctuations stop. This can be done only on auto mode.
- b. The Carbon may be worn out and is causing sparking on the track. Change the carbon.
- c. Check for any loose connection on the input or the output side.

3) Continuous Rattling/hunting sound

- a. Adjust respective Pot on Servo Controlled Card. Keeping switch in 'auto' mode.
- b. The Gear on the motor and the main gear mis - matching. Adjust the Motor by loosening it four holding screws and moving the motor to match the two gears. Tighten the motor in the correct position.

4) Output Voltage not regulating

- a. Put the switch in manual mode and try to raise or lower the output voltage.
- b. Check if the motor is running. In case no change in voltage occurs, the gear on the motor shaft is definitely not matching with the main gear. Please do the needful as explained above.
- c. Put the switch in auto mode after correction. If still not regulating to the correct value the control card may be defective. Before removing the control card pl see arrangement for shorting terminal if any to check the output voltage. If still no function in output voltage occurs, change the card.
- d. The voltage adjust pot provided on the front panel may be open, change the pot.

5) Tank overheating beyond limits (In case of oil cooled Servo

Controlled Voltage Stabilizer)

- a. Check for over-loading on all three phases. The normal temperature of the oil should not be more than 45 degree centigrade above the ambient. If the temperature is more there may be some short in the winding. Thus, requiring a major repair.
- b. The oil level might have fallen due to some leakage and this can also result in overheating.

Common faults & Probable Reasons...

Sr.No	Fault	Probable Reasons
1	Ref unit is not switching ON	<ul style="list-style-type: none"> No power supply Main switch turned off No output from Servo voltage stabilizer. Unit circuit breaker in OFF position Defect in Generator Panel Defect in Cold room Panel O.L.P. defective Starting device/Capacitor defective (in case of single phase compressor) Unit contactor defective Compressor defective Thermostat/ Digital Temperature Controller defective Pressure switch defective Unit tripped on HP/LP or HP
2	Compressor is running but no cooling	<ul style="list-style-type: none"> Blockage in system Insufficient refrigerant Gas leakage in system Defective compressor valve Less pumping Moisture blockage Leakage from service valve. Compressor tripping on HP/LP Solenoid valve is leaking.(In case of WIF,supplied with Hot Gas Bypass defrosting system)
3	Compressor defective	<ul style="list-style-type: none"> Taking high amps Winding open Winding ground Compressor jam Pumping failure
4	Poor refrigeration	<ul style="list-style-type: none"> Thermostat faulty Defective compressor valve Incorrect thermostat/digital temperature controller setting Evaporator needs defrosting Large quantity of fresh load is inserted Partial blocking Moisture blockage Compressor pumping weak
5	Excessive refrigeration	<ul style="list-style-type: none"> Thermostat defective Insufficient refrigerant Incorrect thermostat setting Thermostat sensor position is incorrect.

Sr.No	Fault	Probable Reasons
6	Unit trips on HP	<ul style="list-style-type: none"> Condenser fan motor jam Condenser fan motor burnt Condenser fan motor Starting capacitor weak/defective. Incorrect setting of HP/LP Heavy dust formation on condenser fan motor grill.
7	Frost formation	<ul style="list-style-type: none"> Evaporator fan jammed / burnt Defrost timer may defective No defrost signal from digital temperature controller (if unit is equipped with DTC) Defrost interval too long Defrost duration too short Solenoid valve is defective (In Hot Gas bypass system) Defrost heater are not working Equipment not defrosted periodically
8	Generator fails to start	<ul style="list-style-type: none"> No fuel in engine Oil pressure is low High engine temperature Low battery Starting solenoid defective Series fuse of battery positive is blown (if any) Starter motor problem Ignition coil problem (petrol engine) Existence of alarm condition AMF panel. AMF panel fault.

Notes



Spare parts
and Tool kit





Spares....

The enlisted spares are common, fast moving & generic in nature...

Specifications may differ model to model.

WIC/WIF

- Compressors
- Relay/Start & Run Capacitors (If compressor is single phase)
- Condenser Fan Motor
- Evaporator Fan Motor.
- Capacitors for Condenser/evaporator fan motors.
- Electrical Regulator (Digital Temp Controller)
- Ambient Sensor /Defrosting Sensor
- HP/LP Switch
- HP Switch
- Defrost Solenoid Valve
- Liquid Line Solenoid Valve
- Defrost heaters
- Door heaters & gasket
- Refrigerant (Most of WIC/WIF manufacturer are preferring R404a¹)
- Compressor oil
- Drier Filter
- Capillary/Copper Tubes of appropriate diameter
- Contactor
- Circuit Breakers
- Selector Switches
- Fuses

Miscellaneous Components (Temperature Recorders/Alarm Systems)

- Temperature recording chart
- Ink capsules
- Cell
- Battery
- AC adopters



DG SET

Engine

- Start & Stop solenoid
- Starter motor
- Power relays
- Fuel filter
- Air filter
- Oil filters

Alternator

- Diode bridge assembly
- AVR
- Brushes
- 1 - Please refer Annexure III

AMF panel

- Contactor
- Relays
- Fuses
- Circuit Breakers
- Selector Switches
- Measuring instruments
- Controllers
- Push buttons
- Indicators

Servo Stabilizer spares-

- Printed Circuit Boards (PCBs)
- (Low voltage Relay (LVR)
- High voltage Relay (HVR) or Triac Control
- Servo Motor
- Series Transformer
- Miniature Circuit Breakers (MCBs)
- Motorised or Double wound variac
- Contactors
- Transformers
- RC networks
- Measuring Instruments (Precision type meters)
- Switches
- Carbon brushes
- Indicating pilot lamps
- Auto manual control switch

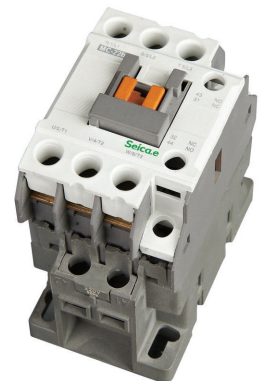

Tool kit

Details Technical Specification – Refrigeration and General tools

Sr. No.	Name of Tool	Technical specification & Features	Image
1	Tube bender	Triple head lever type tube bender in the various sizes 1/4", 5/16", 3/8" 370-FH	
2	Hand valve	Two way, 1/4" x 1/4"	
3	Manifold Gauge with standard changing line	<p>For use of Non CFC gases i.e. R134a, R404</p> <p>1/4" union connectors, 4-Valve Efficiency - Vacuum, Gas charge, Low side, High side, and three colour coded high efficiency refrigerant hoses are individually connected and controlled.</p> <p>Deep Vacuum Valve Design – Diaphragm-type, For complete closing, soft-seat valves mechanism which requires only fingertip pressure. Full opening/closing with One turn only. Must be Suitable for deep vacuum service.</p> <p>Precision Gauges & Protective Boots</p> <p>The design should be Unique with easy to read color-coded scales with superior resistance to shock, vibration, pulsation for superior performance and extended gauge life.</p> <p>Withstanding Pressures. 600 PSI working pressure/3,000 PSI burst pressure.</p>	
4	Flaring and Swaging tool	<p>Bar and Yoke</p> <p>Easy operations for Flares and swedges. Screw-type feed. Suitable for close quarters operations.</p> <p>Flaring cone Self-centering, slip-on forged steel yoke. Two bars covering 9 flare sizes.</p> <p>Flares 1/8", 3/16", 1/4", 5/16", 3/8", 7/16", 1/2", 5/8" and 3/4" OD</p> <p>The swaging adapters should be of Swivel-type. 5 swage adapters for 7 tube sizes: 3/16", 1/4", 5/16", 3/8", 1/2", 5/8", 3/4" O.D. with swaging bits 3/16" to 5/8"</p> <p>To accommodate flare/swedge tools the tool case with set is mandatory.</p>	
5	Line tap and control valve (piercing valve)	Two way, size - 1/4",	
6	Line tap and control valve (piercing valve)	Two way, size - 3/16"	
7	Pinch off pliers	Material -Stainless steel, Size- 8"	

Sr. No.	Name of Tool	Technical specification & Features	Image
8	Gas charging Unit (Charge check)	Suitable for accurate gas charging with the use of calibrated pressure-temperature/volume scale. The accuracy needed is 2%. Protection required. Safety relief valve Plastic liquid level indicators with steel carrying case.	
9	Tube cutter miniature	Should be of capacity to cut 1/8" to 5/8" OD tubing in tight quarters.	
10	Capillary tube sizer	Suitable for measuring commonly used capillary tube ID sizes in inch (.028, .031, .036, .039, .042, .046, .050, .055, .064, .070)	
11	Vacuum pump	Rating -220 v, 50/60 Hz, 1/4 HP, II stage, 1.5 CFM	
12	Tong tester	Accuracies are \pm (% reading + number of digits) at $27 \pm 5^{\circ}\text{C}$ Humidity =less than 75% RH. AC Current (50-60Hz) Range = 40 A/ 100A Accuracy = \pm (3% + 4digit) Overload Protection = 1000A AC Max. for 1 minute DC Voltage (Auto Ranging) Ranges : 4V, 40V, 400V, 1000V AC Voltage (Auto Ranging) 40-500Hz Range : 4V, 40V, 400V, 750V Resolution : 1mV to 1V Resistance (Auto Ranging) Range : (400,4K,40K,400K,4M,40M) Resistance Resolution : 0.1 to 0.01M Continuity Check with Overload Protection=: 500V DC / AC Frequency (Auto Ranging) Range : 10.00Hz, 50.00Hz, 500.0Hz, 5.000kHz, 50.00kHz, 500.0kHz Including features of Diode Test & Capacitance measurement	
13	Valve key	Standard in size to operate service valve used in refrigeration	

Sr. No.	Name of Tool	Technical specification & Features	Image
14	Gas cylinder - 2 kg	Empty with 1/4" service valve, Clearly specifying the cylinder size/pressure rating/tare weight & class. Cylinder should be marked for its maximum operating pressure. High quality, with overfill protection instructions,	
15	Multimeter	Ranging: AUTO, MANUAL, Operating Temperature Range: 5 to 40°C Parameter measuring range.... DC Voltage (DC V) =200 mv-200V DC Current (DC A)=2mA-200mA Resistance (OHM)=200 ohm-200M AC Voltage(AC V)=200mV-700V AC Current (AC A)=2mA-2000mA With standard accessories.	
16	Brazing Torch	LPG gas operated with disposable cylinder,	
17	Non Return Valve (NRV)	1/4", with 8" copper tube	
18	Capillary tube shear	Suitable for commonly used capillary tube sizes 0-4 mm	
19	Mirror	SS, Dentist, adjustable up to 8"	
20	Tool for removal of scrapper valve	Standard size in any metal	
21	Electronic thermometer	Digital, Temperature range - 50°C to + 50°C , Accuracy + or - 1°C, 2.5 digit, CE marking	
22	Valve for disposable refrigerant cylinder	Suitable for regular Service cylinder capacity-1 kg	
23	Refrigerant Recovery unit	Suitable for use of Non CFC gases R134a, R404, 4-Valve Efficiency - Vacuum, Gas charge, Low side, High side, and two colour coded high efficiency refrigerant hoses are individually connected and controlled. Charging lines test pressure minimum 250 bars. Should be equipped with 1.Suitable size sealed compressor, 2.Standard size condenser, 3.High quality drier, 4.HP/LP switch, 5. liquid indicator, 6. 1/4" union connectors, And supplied along with 5 Kg capacity empty cylinder with service valve operation.	

General Tools		
Sr. no.	Name of Tool	Technical specification
1	spanner set	Set of 8 pieces, One side and one side open end – 6/7 to 20/22 mm, 6 x 7, 8 x 9, 10 x 11, 12 x 13, 14 x 15, 16 x 17, 18 x 19, 20 x 22
2	Adjustable spanner	6", Phosphate Finish
3	Adjustable spanner	12", Phosphate Finish
4	File	Flat with handle – smooth, 8"
5	Multigrip plier	smooth, 8", Chrome vanadium steel
6	File	Round with handle - smooth, 8"
7	Hammer	Ball pen – 2 pounds
8	Hacksaw	Junior, standard size
9	Hacksaw	Regular 18"
10	Plier combination	8" Chrome Vanadium Steel, PVC Coated Handles. Flat jaws with a cutting edge near the fulcrum.
11	Nose pliers	6" Flat-nose, with long, narrow, flat jaws.
12	Chisel cold	4"
13	Centre punch	4"
14	Solder iron	25 watts, High quality
15	Side cutting plier	6" Chrome Vanadium material, Rubber handle
16	Drill machine	Electric -10 mm chuck up to 650 watts,
17	Screw driver set	Philips head (Small & Big) 1 and 2
18	Screw driver	Ordinary slot - set of 5 pieces, 822, 823, 825, 832, 835
19	Allen key set	Set of 9 pieces, Size: (1.5, 10, 2, 2.5, 6, 4, 5, 8, 3) mm, Material -Steel
20	Measuring tape	With roller, 5 Mtrs in length, Rubberized Case, Glare-Free Blade, With Belt Clip, on-Slip Grip, Front Lock.
21	Locking plier	7"
22	Drill bits set	3 mm to 10 mm – High speed
23	Concrete drill bit set	3 to 6 mm – High speed
24	Air blower	650 watt- High speed
25	Leather bag	Executive MR bag, High quality leather and locking facility

Note – The refrigeration/General tools mentioned should be CE or ISO Certified.



Annexures





Annexure I

Refrigeration - Frost and Defrost

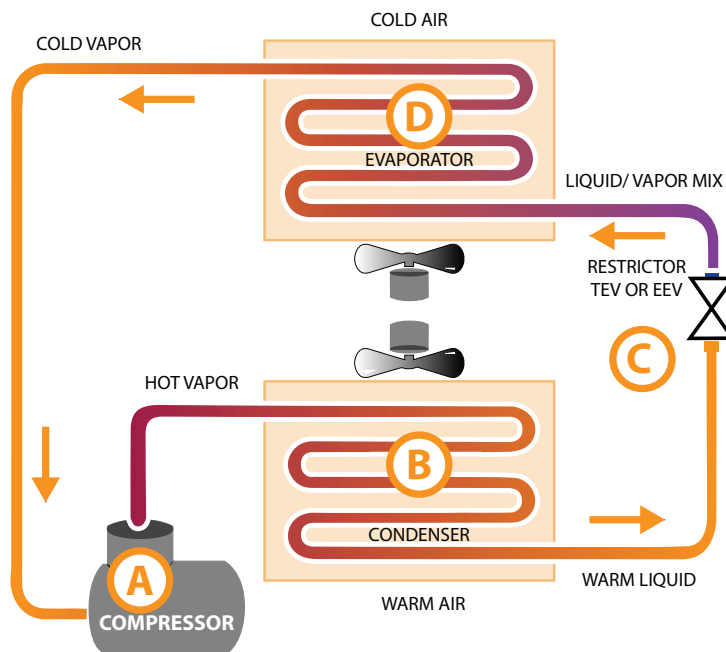

Understanding how and why refrigeration defrost occurs brings to light its essential role in saving on product/installation costs, weight and refrigerant charge.

Figure 1 This image illustrates how the basic vapor compression cycle works

Refrigeration is used to assure proper storage temperature of stored products. This is most often accomplished by using the vapor compression cycle. In this technique, refrigerant vapor is compressed by a compressor, condensed into a liquid in a condenser by the rejection of heat, expanded by a restrictive device, and fed into an evaporator where heat is absorbed and returned to the compressor to complete the cycle (see Figure 1). Most commonly, the evaporator cools air that is then used to cool the product. Due to inefficiencies of the heat-transfer process, the temperature of the refrigerant in the evaporator is 5°F–16°F (3–9 Kelvin) colder than the air temperature. Even products that must be stored above freezing temperatures will require evaporator-surface temperatures below the freezing point of water. Using fresh meat, which is often stored at 34°F–36°F (1°C–2°C), as an example, the evaporator surface will be between 24°F–31°F (-5°C--1°C). Because ice forms at 32°F, the evaporator surface will begin to build a coating of ice referred to as “frost,” which is seen in a number of different forms.

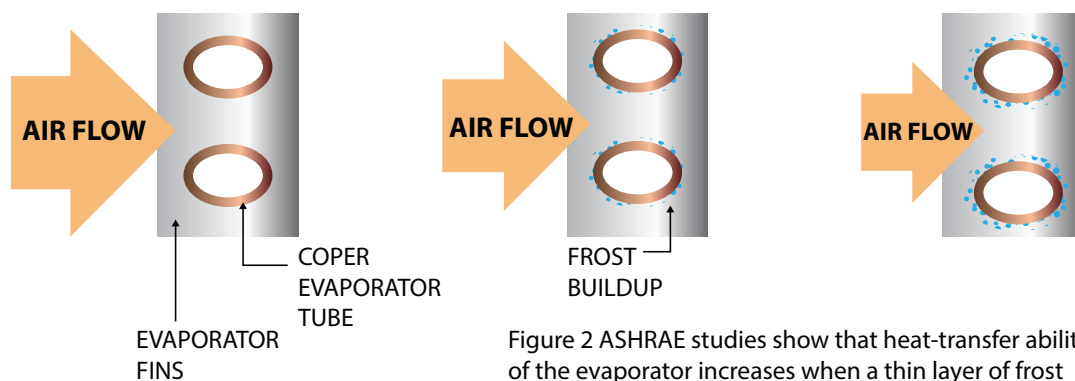

Figure 2 ASHRAE studies show that heat-transfer ability of the evaporator increases when a thin layer of frost develops. this image illustrates that principle.

The layer of frost closest to the surface of the evaporator will tend to be a hard form of ice, similar to ice cubes. Depending on humidity, evaporator temperature and air flow, subsequent layers of frost may be more crystalline or snowlike. This is referred to as "hoar frost." In some instances frost will not begin to form until the coil surface reaches temperatures near 26°F (-5°C), but the need for some defrost is almost universal. Many low-temperature evaporator coils have widely spaced fins to provide space for frost to build before it seriously impedes air flow. Typical spacing for low-temperature evaporators is 4 fins per inch, but not exceeding 6 fins per inch. Medium- or high-temperature evaporators will have 6 to 8 or more fins per inch; while air-conditioning coils may have 12 or more fins per inch. Since heat-transfer capacity is directly related to the surface area of the evaporator, fewer fins per inch will require a physically larger evaporator for a given capacity. Conversely, if frost on the evaporator can be limited to small amounts, it is possible that a smaller and more economical evaporator could be used. Although ice has a thermal conductivity approximately four times that of water (which means it conducts heat four times as well as water), as air becomes entrained in the flaky hoar frost, the frost becomes an insulator and will reduce the evaporator's ability to absorb heat. This insulating effect, along with the restriction of air flow across the frosted evaporator, means that at some point the coil must be defrosted. ASHRAE studies (1998 R42.3—Okarsson, Krakow and Lin 1990: Evaporator Models for operation with dry, wet and

frosted finned surfaces; Part II: Evaporator Models and verification; ASHRAE Transactions 96(1):381-392.) have shown that the heat-transfer ability of the evaporator actually increases when a thin layer of frost develops. This is likely due to the increase in surface area of the tube, and a slight increase in the velocity of the air due to the reduction in area of the air passages through the evaporator. See Figure 2.

Testing has shown that the optimum time to defrost is when the evaporator loses about 10% efficiency. Traditional methods of defrost, based on time, cannot ascertain this loss of efficiency and will either waste time and energy in excessive defrosting, or never fully defrost the evaporator. Each 1 lb of frost or ice melted will contribute an additional 144 Btu of refrigeration. Not only is the evaporator kept at optimum heat-transfer ability, but free cooling and re-humidification is provided. Common methods of defrosting include off-cycle, electric and hot-gas.

Off-cycle defrost

Off-cycle defrost simply involves turning off the refrigeration system while letting the fans run continuously. Since the air must be warmer than 32°F (0°C), off-cycle defrost is only useful on coolers meant for positive temperature. The chief advantage of off-cycle defrost is the simplicity and economy of installation. However, the fans must run during both cooling and defrost mode. This can use more energy than needed for proper cooling.

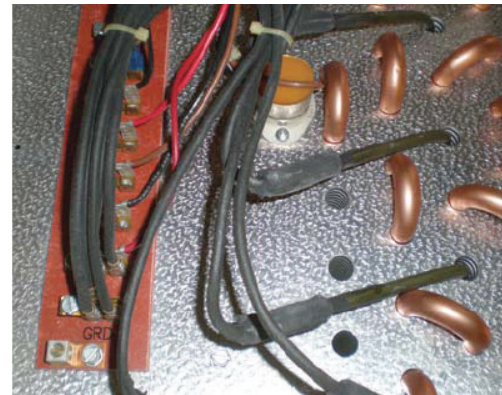

Although easy to install and control, electric defrost can be expensive in terms of energy use.

Electric defrost

The second-most common method of defrosting is by electric heat. The evaporators must be designed and built for this type of defrost and incorporate passages through the evaporator fins, generally parallel to the refrigeration tubing. Long electric-resistance heaters are placed into provided passages and are energized to raise the temperature of the evaporator surface above freezing. Although simple to install and control, electric defrost can be very expensive in terms of energy use. The heaters are energized for the duration of the defrost cycle and can use about 1 kW per foot of evaporator length.

Since standard timed defrosts are usually set for three per day and may last 45–60 minutes, the power consumption can be significant. In addition, the surface temperature of the heater itself can exceed 300°F, and any melted frost that comes into contact with the element will flash into steam and re-condense on cold surfaces in the refrigerated room. Often this will appear as layers of ice on the ceiling of the room, and it will not be removed during a routine defrost. Occasionally, an electric defrost will be extended to try to remove this buildup, keeping the heaters energized beyond the time needed for defrosting the evaporator. This can actually scorch the evaporator or other room components. Electric defrost must be closely controlled to make sure it is as effective and as efficient as possible.

Notes

.....

.....

.....

.....

.....

.....

.....

.....

.....

.....

Hot-gas defrost

The third common type of defrost is hot gas, some versions are known as cool gas. This is the most complex and expensive to install, but the quality and effectiveness of the defrost is better than the other defrost methods. In hot-gas defrost; the liquid refrigerant flowing through the evaporator is interrupted, and instead, a supply of gas directly from the discharge of the compressor is used. This "gas" is really superheated compressed refrigerant vapor and can easily exceed 200°F. Since this hot vapor is actually inside the tubes of the evaporator, it applies heat to the frost where it forms on the tube. The hot gas travels throughout the entire tubing circuit, and will therefore defrost areas of the evaporator that may not be as effectively reached by electric-resistance heaters. In many cases, the flow of the hot gas is in the reverse direction from that of the cooling mode. This is called reverse-cycle hot-gas defrost (see Figures 3 and 4).

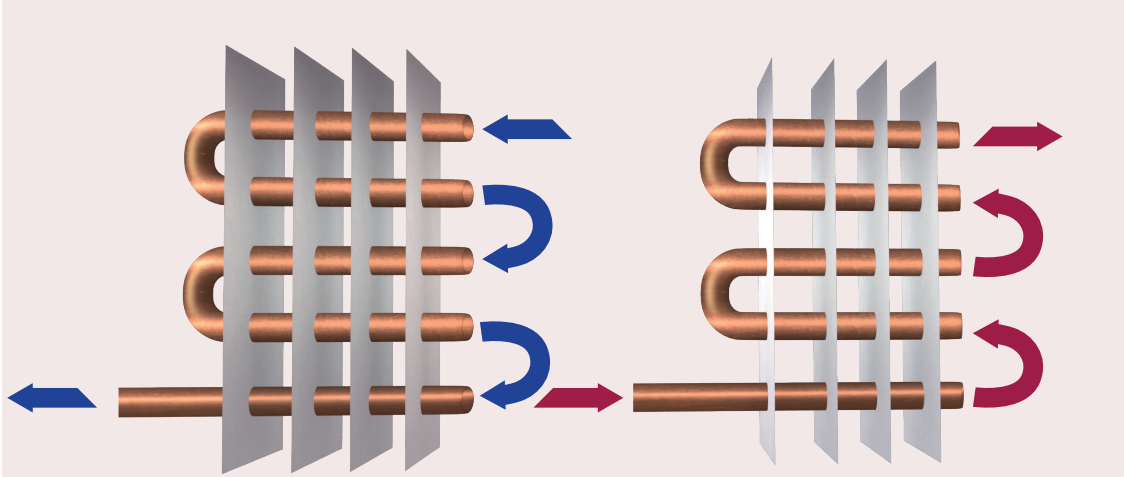

Figure 3 In the cooling mode, liquid refrigerant moves from the evaporator to the compressor.

Figure 4 Reverse-cycle hot-gas defrost, illustrated here, is the primary method used in supermarket refrigeration systems.

Notes

.....

.....

.....

.....

.....

.....

.....

.....

.....

.....

.....

.....

.....

.....

.....

.....

The cool-gas version is essentially the same, except that the gas used for defrosting is obtained from the receiver, rather than directly from the compressor discharge. In either of these two types of defrosts, the fans should not only be off during the defrost cycle, but must be held off for some time after the defrost terminates. During a defrost, water is formed on the evaporator as the ice melts. Once the defrost terminates, the water must be allowed to drain from the coil. This “drip time” prevents moisture from being blown off the coil and refreezing on the cold product or other surfaces in the room. Some evaporators are equipped with a thermostat to delay starting the fans until the coil has dried or gotten cold enough to re-freeze the remaining moisture. Evaporator temperatures below the freezing point of water are often needed to keep foods and other products safe to use and convenient to store. Ice or frost builds up on these evaporators is inevitable but methods to remove it are well proven and easy to implement. Newer technology allows even smarter methods to be applied—now and in the future. As stated earlier, consistent limitation of the amount of frost on the evaporator has a direct saving in installation. Limiting the amount of frost formed and assuring complete defrosting permits the use of a coil with more fins per inch. This, in turn, may allow a physically smaller and less expensive evaporator to be used—saving product cost, installation cost, weight and refrigerant charge.

Notes

A series of horizontal dotted lines for taking notes.

Annexure II

Temperature Mapping in WIC/WIF

1.0 Requirements

Temperature-controlled storage areas i.e.WIC/WIF must be temperature-mapped as part of a fully documented verification process, before the installation is commissioned and handed over by the installer. Until this has been done, it is not safe & recommended to store vaccines in WIC/WIF. The temperature mapping procedures should:

- Demonstrate the air temperature profile throughout the storage area, when empty and in a normal loaded condition;
- Define zones which should not be used for storage of freeze sensitive vaccines (for example areas in close proximity to cooling coils, cold air streams); and
- Demonstrate the time taken for temperatures to exceed the designated limits in the event of power failure.

Subsequent mapping exercises must also be carried out on a periodic basis - for example, every three years - in order to demonstrate continuing compliance. In addition mapping should be carried out whenever significant modifications are made to the WICs/WIFs. Examples include change in the location of indoor units (Replacement of refrigeration units under retrofitting process) may affect the pattern of use that may increase loading or affect air circulation. Finally a re-mapping exercise may be justified whenever an analysis of temperature and/or even humidity monitoring records show unexplained variability outside normal operating limits. All mapping exercises should be fully documented in order to demonstrate compliance to the required test results.

1.2 Objectives

The objective of the Technical Supplement is to provide clear guidance on how to conduct a temperature mapping study in WIC/WIF. This guidance applies to any space designed for long-term or short-term storage of vaccines.

2. Guidance

A temperature mapping exercise is required for any space allocated for the storage and handling of vaccines with a specified desired storage temperature. This includes cold rooms, freezer rooms, temperature-controlled storage areas, receiving and loading bays.

A mapping study establishes the temperature distribution within the zone being mapped and it locates hot and cold spots. The collected data provides an essential source of information to ensure that all vaccines are correctly stored within their safe temperature range(s). Mapping may also be used to identify zones where remedial action needs to be taken; for example, by altering existing air distribution to eliminate hot and cold spots, or by retro-fitting new air distribution equipment to reduce temperature stratification.

A temperature mapping exercise involves a four stage process, as follows:

- a. Prepare a mapping protocol.
- b. Carry out the mapping exercise.
- c. Prepare a mapping report.

Implement the recommendations by carrying out the remedial and other actions identified in the mapping report. A follow-up mapping exercise may then be needed to verify the effectiveness of the remedial actions.

2.1 The mapping protocol

A detailed and comprehensive protocol should be prepared, reviewed and approved before the mapping exercise begins. A well-designed protocol will help ensure that the mapping study is correctly carried out. With suitable adjustments or options to cover the full range of temperature regimes, a standard protocol can be used to map any storage area in the facility.

The mapping protocol should contain the following sections:

- Approval page and change control history.
 - Acronyms and glossary.
 - Description and rationale.
 - Scope
 - Objectives.
 - Methodology
 - Mapping report template.
 - Annexes as needed, including templates for the mapping
- A report the content of each of these sections is detailed below.

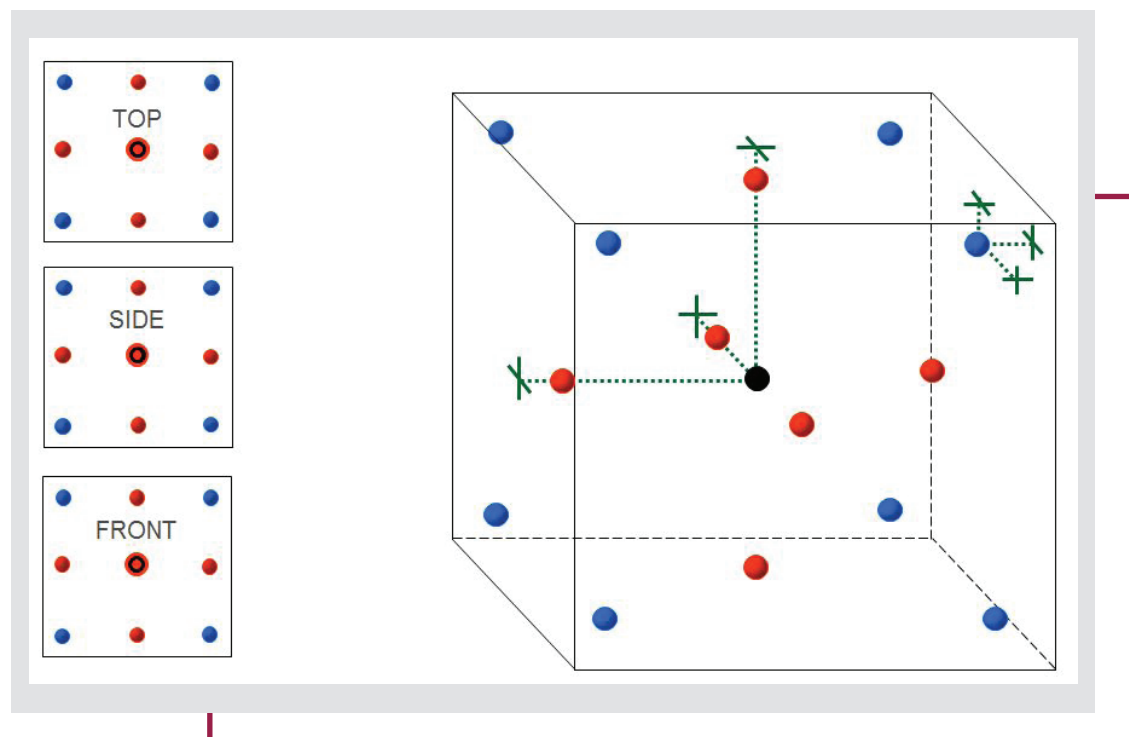

2.2 Approval page and change control history:

Include a standard template for recording approvals and changes to the document. The following is an example:

Approvals			
Authorized by:			
Reviewed by:			
Revised by:			
Original author:			

2.2.1 Scope:

Clearly define the scope and purpose of the mapping study. The fundamental purpose is to identify temperature deviations affecting the chosen storage area(s) at the time the study is being conducted, so that remedial action can be taken. Preferably, at least two temperature mapping studies should be carried out in each area. In order to observe the effect of seasonal variation, one should be carried out during the warmest season and one during the coldest season. This will establish whether the mapped area is able to maintain stable temperatures throughout the year.

The results of the two studies can be compared so that systematic seasonally-related issues can be identified. These seasonal effects need to be separated out from any other site-specific issues arising at the times when the comparative studies are carried out.

2.2.2 Objectives:

Clearly define the detailed objectives of the study, as follows:

- Mapping temperature variations within the selected storage areas. Typically these areas include cold rooms, freezer rooms, packing areas, receiving & loading bays and or are held when in transit.
- Measuring temperature variations at each location within the chose area, by day of the week, and time of day.
- Documenting high and low temperature fluctuations caused by the environmental control systems operating at the time of the study - for example, heating, cooling and ventilation.
- Identifying potential airflow issues that may be the cause of temperature variations.
- Recommending where vaccines can safely be stored in the mapped area. These recommendations should take account of any temperature deviations identified during the study as well as the safe temperature range(s) for the vaccines being stored.
- Identifying the best places to locate temperature sensors, for routine monitoring, in circumstances in which a monitoring system is installed. If a monitoring is already installed, identify the best places to re-locate temperature sensors (if necessary).
- Making recommendations for any remedial actions needed to overcome the problems identified in the study.

2.2.3 Methodology

The following steps outline the methodology for conducting a temperature mapping study.

STEP 1 Select Data Loggers

Select the type of Data Loggers to be used. Choose a device that has sufficient memory for the intended duration of the study and the selected recording interval. All loggers must have pre calibrated & have an error of not more than $\pm 0.5^{\circ}\text{C}$ at each calibration point. Valid calibration certificates for each of the data loggers used in the study must be included in the mapping report. Some Data loggers with built-in batteries and a limited life are not designed to be re-calibrated; otherwise calibration should be done annually.

Calibration temperature points should be based on the required temperature range for each of the areas being studied. In general, there should be one calibration point below the low end of the range, one calibration point in the middle of the range, and one calibration point above the high end of the range.

To ensure consistency, use only one type of device per mapping study. Provide a link to the manufacturer's user instructions so that those responsible for programming and reading the devices understand how to perform these actions correctly.

STEP 2 Designate the mapping team

Identify and list the team members. Record their signatures and initials so that signed records can be traced back to the person who prepared the document. Ensure that all team members receive the training needed to perform their assigned tasks.

STEP 3 Survey the site

Conduct a survey of the equipment(s) to be mapped. The following information is required for each thermally separate area being mapped:

- Length, width and height dimensions.
- Drawing of each area, showing elements, such as shelving or pallet racking, that may have an effect on the even heating or cooling of the space and which may have an effect on its temperature stability. The shelving or pallet racking will be used to place the Data Loggers, so it is important to record these components accurately.
- The location of cooling and heating (if there any) components, including air distribution outlets and/or ceiling fans.
- The location of existing temperature recording sensors and temperature controlling sensors.

STEP 4 Establish acceptance criteria

Generally speaking the protocol should define the required acceptance criteria, based on the type of vaccines being stored, clearly stating the temperature limits that are allowable within the area to be mapped - for example: $+2^{\circ}\text{C}$ to $+8^{\circ}\text{C}$ or -15°C to -25°C , and what remedial actions might have to be carried out to improve the thermal performance of the space in order to optimize its use.

STEP 5 Determine Data Loggers locations

Use the site survey to mark the required locations of the Data Loggers. The following guidelines will help determine the number and location of the Data Loggers required:

Data Loggers should be arranged in a grid fashion along the width and length of the area so that the area is reasonably covered, with Data Loggers locations every 5-10 metres. The chosen sensor grid should take account of:

- The layout of the area
- The degree to which shelving and vaccines may affect airflow.
- Where products are placed. The positions of Data Loggers should coincide with locations where vaccines are actually stored or planned to be stored.
- Other considerations that may warrant more or fewer Data Loggers.
- Give each logger location a unique ID. It may be helpful to use a generic floor plan or diagram to decide where each logger should be positioned – see Figure shows a small walk-in cold room.

Typical location of data loggers in a walk-in cold room

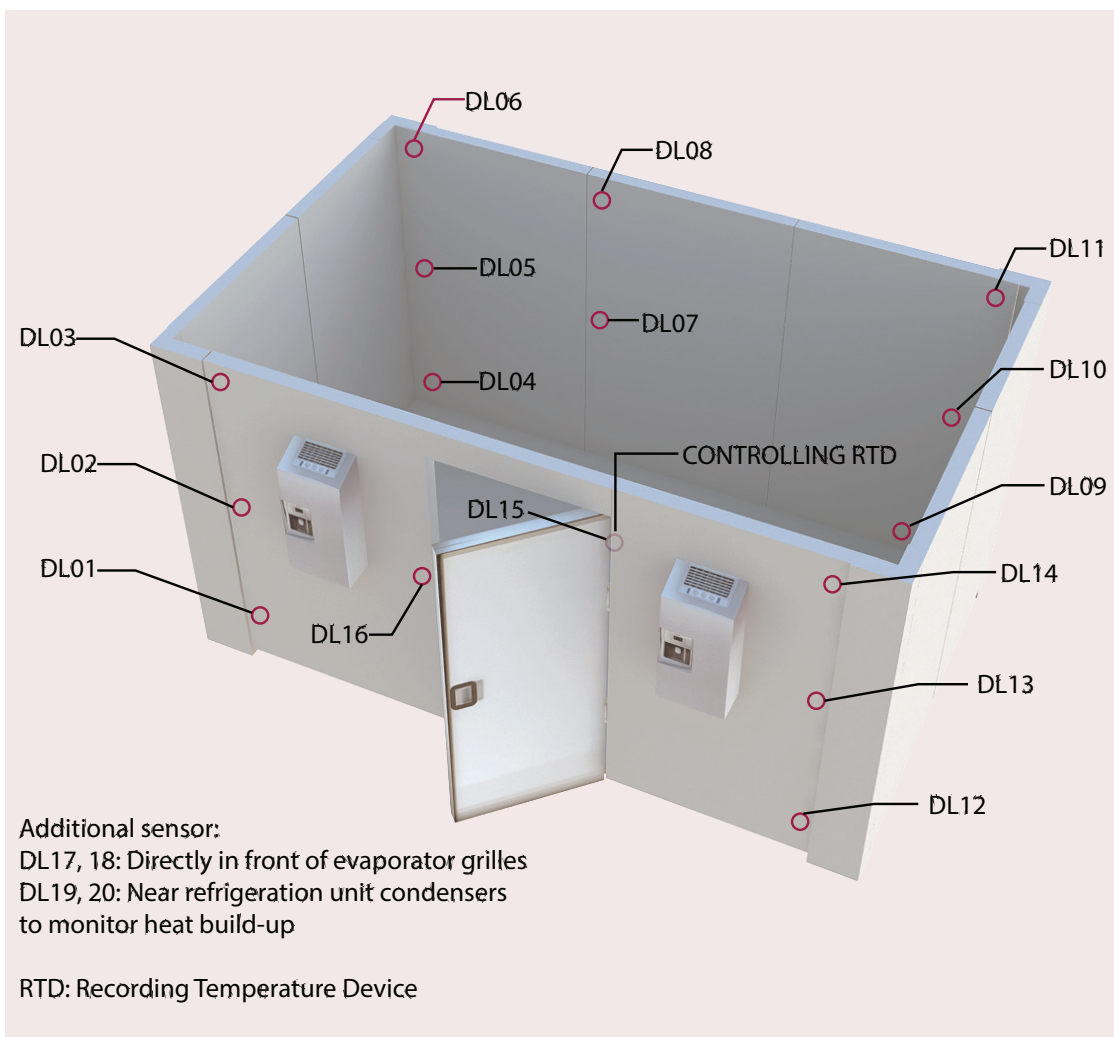

STEP 6 Record Data Logger and thermostat locations

Record the Data Logger locations on a temperature data logger location table - see example in **Annex 1.1**. Also record the location identification and set point for each thermostat in the mapping area - see example in **Annex 1.2**.

STEP 7 Label and program the Data Loggers

Label each Data Logger with a unique ID, taken from the temperature data logger location table. Enter the manufacturer's serial number on the temperature data logger location table (Annex 1.1). Recording the serial number ensures that the device can be traced to its calibration certificate. Program each device, ensuring that the recording interval is the same - typically this should be set between 5 and 15 minutes. Set the same start time for all units. This is essential; otherwise the downloaded readings from the individual devices cannot be time-correlated. Make sure that the start time setting gives you enough time to fix all the units in position before recording begins.

STEP 8 Fix Data Loggers in position

Fix the Data Loggers in position. Make sure that each one is placed exactly as shown on the temperature data logger location table and drawing. Position and fasten the devices so that they cannot be damaged or displaced during the course of routine store operations.

STEP 9 Conduct the mapping exercise

There is no formal time limit for a mapping study. Typically it should be run for a minimum of seven to 10 consecutive days for WICs and WIFs. For WICs/WIFs which is not critically affected by diurnal or seasonal variations in ambient temperature the mapping study should be run for between 24 and 72 hours, or more if justified. WIC/WIF is fitted with duplicate refrigeration units - with or without automatic changeover - it is essential to map temperatures over a period that includes the operation of both units; preferably for a similar time period. The temperature distribution in the room may vary depending upon which system is running. At the end of the study, collect the Data Loggers and double-check their serial numbers and locations against the installation notes.

STEP 10 download and consolidate the data

Download the Data Loggers readings and consolidate the data for the study analysis described in Section 2.4.

Notes

.....

.....

.....

.....

.....

.....

.....

2.2.4 Mapping report template

The protocol should contain a template for the mapping report. This should include the sections listed below:

- a. Introduction: a description of the objectives of the mapping study.
- b. Summary: a summary and discussion of the results organized in the sequence set out in the mapping protocol, including a summary of deviations (if any).
- c. Conclusions and recommendations: a general conclusion for all verifications and observations indicating the acceptability of the equipment for operation. Recommendations and remarks can be incorporated as well.
- d. Report annexes: The report annexes should contain the following:
 - » The site survey, showing Data Loggers locations.
 - » The raw data, presented using the appropriate test data sheet format – see Annex 1.
 - » Spreadsheet data and related temperature graphs for every Data Loggers used in the mapping exercise.
 - » Raw results of the data analysis.
 - » Key documents and notes prepared during the mapping exercise, together with any other supporting material.
 - » Deviation reports, including Corrective and Preventive Actions (CAPA) forms, if required.
 - » Calibration certificates for all Data Loggers used.

Duplicate units are sometimes set up so that one system runs most of the time and the other only cuts in at a higher temperature. This ensures that the second unit runs infrequently and therefore reduces the chances of a simultaneous breakdown.

2.3 Conducting the mapping exercise

Conduct the mapping exercise in accordance with the protocol. Ensure that all relevant personnel in the store are fully briefed so as to avoid inadvertent disruption or deactivation of the Data Loggers. At the end of the study period, collect all the devices, deactivate them, and download the data for analysis.

2.4 Analyzing the data and preparing the mapping report

The mapping report should follow the general framework outlined in Section 2.2.4. The following sub-sections outline the data analysis process that precedes the writing of the report.

Notes

.....

.....

.....

.....

.....

.....

.....

2.4.1 Preliminary analysis

Analyze the overall temperature stability of the study area and identify the variations that occur. Compare the measured temperatures against the acceptance criteria. The analysis of the overall temperature stability should consider factors such as:

- The ability of the environmental control systems to maintain temperatures within the acceptance criteria limits (if any).
- The overall temperature stability of the area being monitored, and the range in fluctuations it experiences over the study period.

The analysis of temperature variations should consider factors such as:

- Variations experienced by individual Data Loggers.
- Temperature variations along vertical and horizontal planes, depending on the size of the area, and distribution of Data Loggers.
- Temperature variations in locations close to heating and cooling components, as compared to those farthest away from these units

Notes

A large rectangular area with a light gray background, containing horizontal dashed lines for taking notes.

Test data sheets

The following sections show examples of the type of data collection forms used in a mapping exercise.

A1.1 Test data sheet: temperature data logger locations

Data Logger ID Number	Data Logger Serial No	ID no on scheme	Mounting Height	Description/Comments
DL-001		1	0.3	
DL-002		2	2.8	
DL-003		3	5.4	

A 1.2 Test data sheet: temperature distribution

Thermostat Information		
Location	Set Point	Comment

A 1.3 Test data sheet: temperature distribution

Data Logger ID No.	Min Temp Recorded (°C)	Max Temp Recorded (°C)	Mean Temp (°C)	Within Range		Inspected by	Date
				Yes	No		
DL -001							
DL-002							
Mapping period starts at (date/hour):							
Mapping period ends at (date/hour)							
Checked by:				Date:			

Annexure IV

R-404A

General Description

Refrigerant Gas R404A is a colorless odorless mixture of three hydro fluorocarbon compounds in near-azeotropic proportions. Azeotropic mixtures have sharp boiling points instead of boiling over a range of temperatures, which is the case with most mixtures. Boiling point (at 1 atm) -46.5°C. Density (as a liquid) 0.485 kg/L. Shipped as a liquid under its own vapor pressure. The vapors are heavier than air and can cause asphyxiation by the displacement of air. Contact with the liquid can cause frostbite. Prolonged exposure to fire or intense heat may cause the containers to rupture violently and rocket.

It is a blend of HFC refrigerants commonly used for medium and low temperature refrigeration applications.

Its composition comprises:

- Pentafluoroethane** HFC-125 (44%),
- 1,1,1-Trifluoroethane HFC-143a (52%),
- 1,1,1,2-Tetrafluoroethane HFC-134a (4%).

It is non toxic and non flammable

POTENTIAL HEALTH HAZARDS

- **SKIN:** Irritation would result from a defatting action on tissue. Liquid contact could cause frostbite.
- **EYES:** Liquid contact can cause severe irritation and frostbite. Mist may irritate.
- **INHALATION:** R-404A is low in acute toxicity in animals. When oxygen levels in air are reduced to 12-14% by displacement, symptoms of asphyxiation, loss of coordination, increased pulse rate and deeper respiration will occur. At high levels, cardiac arrhythmia may occur.
- **INGESTION:** Ingestion is unlikely because of the low boiling point of the material. Should it occur, discomfort in the gastrointestinal tract from rapid evaporation of the material and consequent evolution of gas would result. Some effects of inhalation and skin exposure would be expected.
- **DELAYED EFFECTS:** None known.

FIRST AID MEASURES

- **SKIN:** Promptly flush skin with water until all chemical is removed. If there is evidence of frostbite, bathe (do not rub) with lukewarm (not hot) water. If water is not available, cover with a clean, soft cloth or similar covering. Get medical attention if symptoms persist.

- **EYES:** Immediately flush eyes with large amounts of water for at least 15 minutes (in case of frostbite water should be lukewarm, not hot) lifting eyelids occasionally to facilitate irrigation. Get medical attention if symptoms persist.
- **INHALATION:** Immediately remove to fresh air. If breathing has stopped, give artificial respiration. Use oxygen as required, provided a qualified operator is available. Get medical attention. Do not give epinephrine (adrenaline).
- **INGESTION:** Ingestion is unlikely because of the physical properties and is not expected to be hazardous. Do not induce vomiting unless instructed to do so by a physician.
- **ADVICE TO PHYSICIAN:** Because of the possible disturbances of cardiac rhythm, catecholamine drugs, such as epinephrine, should be used with special caution and only in situations of emergency life support. Treatment of overexposure should be directed at the control of symptoms and the clinical conditions.

FIRE FIGHTING MEASURES

FLAMMABLE PROPERTIES

- **FLASH POINT:** Not applicable
- **FLASH POINT METHOD:** Not applicable
- **AUTOIGNITION TEMPERATURE:** <750°C
- **UPPER FLAME LIMIT (volume % in air):** None
- **LOWER FLAME LIMIT (volume % in air):** None
- **FLAME PROPAGATION RATE (solids):** Not applicable
- **FLAMMABILITY CLASS:** Not applicable
- **EXTINGUISHING MEDIA:** Use any standard agent - choose the one most appropriate for type of surrounding fire (material itself is not flammable)

Notes

.....

.....

.....

.....

.....

.....

.....

.....

.....

.....

.....

.....

.....

.....

.....

.....

UNUSUAL FIRE AND EXPLOSION HAZARDS:

R-404A is not flammable at ambient temperatures and atmospheric pressure. However, this material will become combustible when mixed with air under pressure and exposed to strong ignition sources.

Contact with certain reactive metals may result in formation of explosive or exothermic reactions under specific conditions (e.g. very high temperatures and/or appropriate pressures).

SPECIAL FIRE FIGHTING PRECAUTIONS/INSTRUCTIONS:

Fire fighters should wear self-contained, breathing apparatus for protection against possible toxic decomposition products. Proper eye and skin protection should be provided. Use water spray to keep fire-exposed containers cool.

ACCIDENTAL RELEASE MEASURES

IN CASE OF SPILL OR OTHER RELEASE: (Always wear recommended personal protective equipment.)

Evacuate unprotected personnel. Protected personnel should remove ignition sources and shut off leak, if without risk, and provide ventilation. Unprotected personnel should not return until air has been tested and determined safe, including low-lying areas.

Spills and releases may have to be reported to local authorities.

HANDLING AND STORAGE

NORMAL HANDLING: (Always wear recommended personal protective equipment.)

Avoid breathing vapors and liquid contact with eyes, skin or clothing. Do not puncture or drop cylinders, expose them to open flame or excessive heat. Use authorized cylinders only. Follow standard safety precautions for handling and use of compressed gas cylinders.

R-404A should not be mixed with air above atmospheric pressure for leak testing or any other purpose.

STORAGE RECOMMENDATIONS:

Store in a cool, well-ventilated area of low fire risk and out of direct sunlight. Protect cylinder and its fittings from physical damage. Storage in subsurface locations should be avoided. Close valve tightly after use and when empty.

Notes

.....
.....
.....
.....
.....
.....
.....

EXPOSURE CONTROLS / PERSONAL PROTECTION

ENGINEERING CONTROLS:

Provide local ventilation at filling zones and areas where leakage is probable. Mechanical (general) ventilation may be adequate for other operating and storage areas.

PERSONAL PROTECTIVE EQUIPMENT

SKIN PROTECTION:

Skin contact with refrigerant may cause frostbite. General work clothing and gloves (leather) should provide adequate protection. If prolonged contact with the liquid or gas is anticipated, insulated gloves constructed of Polyvinyl Alcohol (PVA), neoprene or butyl rubber should be used. Any contaminated clothing should be promptly removed and washed before reuse.

EYE PROTECTION:

For normal conditions, wear safety glasses. Where there is reasonable probability of liquid contact, wear chemical safety goggles.

RESPIRATORY PROTECTION:

None generally required for adequately ventilated work situations. For accidental release or non-ventilated situations, or release into confined space, where the concentration may be above the PEL (permissible exposure limit) of 1,000 ppm, use a self-contained, breathing apparatus or supplied air respirator.

PHYSICAL AND CHEMICAL PROPERTIES

- APPEARANCE: Clear, colourless liquid and vapour
- PHYSICAL STATE: Gas at ambient temperatures
- MOLECULAR WEIGHT: 120
- CHEMICAL FORMULA: CHF_2CF_3 , CH_3CF_3 , CH_2FCF_3
- ODOR: Faint ethereal odor
- SPECIFIC GRAVITY (water = 1.0): 1.08 @ 21.1°C (70°F)
- SOLUBILITY IN WATER (weight %): Unknown
- pH: Neutral
- BOILING POINT: -47.8°C (-54.0°F)
- FREEZING POINT: Not Determined
- VAPOR PRESSURE: 182.9 psia @ 70°F
- 370.9 psia @ 130°F
- VAPOR DENSITY (air = 1.0): 3.43
- EVAPORATION RATE: > 1 COMPARED TO: CC14 = 1
- % VOLATILES: 100
- FLASH POINT: Not applicable

STABILITY AND REACTIVITY

NORMALLY STABLE? (CONDITIONS TO AVOID):

The product is stable. Do not mix with oxygen or air above atmospheric pressure. Any source of high temperature, such as lighted cigarettes, flames, hot spots or welding may yield toxic and/or corrosive decomposition products.

INCOMPATIBILITIES:

(Under specific conditions: e.g. very high temperatures and/or appropriate pressures)
- Freshly abraded aluminium surfaces (may cause strong exothermic reaction).
Chemically active metals: potassium, calcium, powdered aluminium, magnesium and zinc.

HAZARDOUS DECOMPOSITION PRODUCTS:

Halogens, halogen acids and possibly carbonyl halides.

HAZARDOUS POLYMERIZATION:

Will not occur.

404A PRESSURE-TEMPERATURE

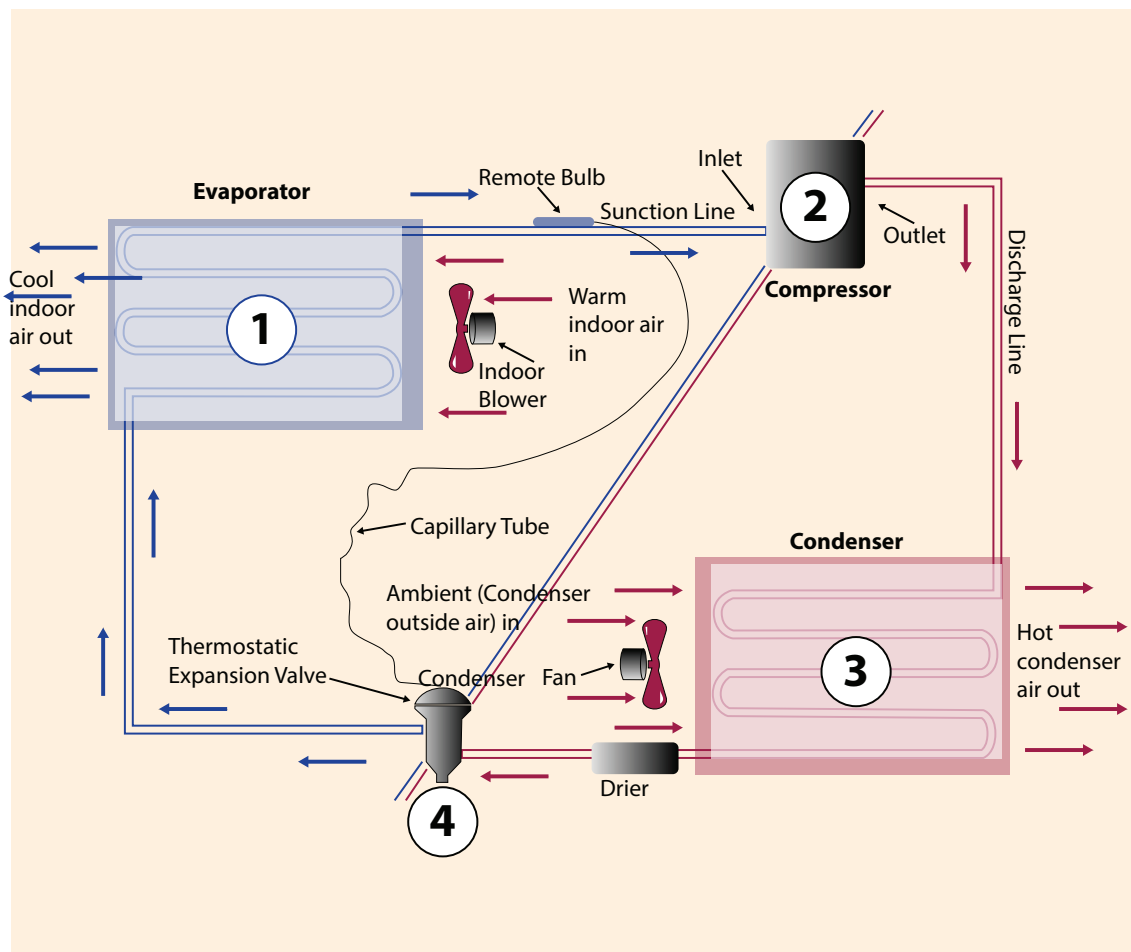

SYSTEM PROBLEM	DISCH PRESS	SUCT PESS	SUPERHEAT	SUBCOOLING	AMP DRAW
OVERCHARGE	HIGH	\	\	HIGH	HIGH
UNDERCHARGE	\	LOW	HIGH	\	\
LIQUID RESTRICT.	\	LOW	HIGH	\	LOW
LOW EVAP FLOW	\	LOW	LOW	\	\
DIRTY CONDENSER	HIGH	\	\	\	HIGH
LOW AMBIENT°F	LOW	LOW	HIGH	HIGH	\
TXV BULB BAD	\	LOW	HIGH	\	\

WHAT IS SUPERHEAT & SUBCOOLING AND HOW TO MEASURE IT

Superheat refers to the number of degrees a vapor is above its saturation temperature (boiling point) at a particular pressure.

Superheat is determined by taking the low side pressure gauge reading, converting that pressure to temperature using a PT chart, and then subtracting that temperature from the actual temperature measured (using an accurate thermometer or thermocouple) at thae same point the pressure was taken.

Subcooling is the condition where the liquid refrigerant is colder than the minimum temperature (saturation temperature) required to keep it from boiling and, hence, change from the liquid to a gas phase.

Subcooling is determined by taking the high side pressure gauge reading, converting that pressure to temperature using a PT chart, and then subtracting that temperature from the actual temperature measured (using an accurate thermometer or thermocouple) at thae same point the pressure was taken.

Notes

R-134a TEMPERATURE PRESSURE CHART		
Ambient Temperature °F/°C	Low-Pressure	High-Pressure Gauge
65°F(18°C)	25-35 psi/172-241 kPa	135-155 psi/ 931-1069 kpa
70°F(21°C)	35-40 psi/241-276 kPa	145-160 psi/1000-1103 kpa
75°F(24°C)	35-45 psi/241-310 kPa	150-170 psi/1034-1172 kpa
80°F(27°C)	40-50 psi/276-345 kPa	175-210 psi/1207-1448 kpa
85°F(29°C)	45-55 psi/310-379 kPa	225-250 psi/1551-1724 kpa
90°F(32°C)	45-55 psi/310-379 kPa	250-270 psi/1724-1862 kpa
95°F(35°C)	50-55 psi/345-379 kPa	275-300 psi/1896-2068 kpa
100°F(38°C)	50-55 psi/345-379 kPa	315-325 psi/2172-2241 kpa
105°F(41°C)	50-55 psi/345-379 kPa	330-335 psi/2275-2310 kpa
110°F(43°C)	50-55 psi/345-379 kPa	340-345 psi/2344-2379 kpa

Ambient temp is the outside atmospheric temperature.

404A PRESSURE-TEMPERATURE CHART

°F	R404A
-50	0.6
-45	2.7
-40	5
-35	7.6
-30	10.4
-25	13.4
-20	16.8
-15	20.5
-10	24.5
-5	28.8
0	33.5
5	38.6
10	44
15	49.9
20	56.2
25	63
30	70.3
35	78.1
40	86.4
45	95.2

°F	R404A
50	104.7
55	114.7
60	125.3
65	136.6
70	148.6
75	161.2
80	174.6
85	188.8
90	203.7
95	219.4
100	235.9
105	253.4
110	271.7
115	290.9
120	311.1
125	332.3
130	354.5
135	377.8
140	402.2
145	427.7
150	454.4

GENERAL SAFETY TIPS & GUIDELINES

GENERAL SAFETY TIPS

- Safety glasses with side shields must be worn at all times.
- Do not wear loose clothing, loose neckwear or exposed jewelry while operating machinery.
- Pull back and secure long hair. (Use hair net or ball cap)
- Do not wear thin fabric shoes, sandals, open-toed shoes, and high-heeled shoes.
- A machinist's apron tied in a quick release manner should be worn.
- Always keep hands and other body parts a safe distance away from moving machine parts, work pieces, and cutters.
- Use hand tools for their designed purposes only.
- Report defective machinery, equipment or hand tools to supervisor.

SAFETY GUIDELINES:

Fire Extinguisher

When used properly, a portable fire extinguisher can save lives and property by putting out a small fire or controlling it until the fire department arrives. Portable extinguishers, intended for the home, are not designed to fight large or spreading fires. However, even against small fires, they are useful only under certain conditions:

- The operator must know how to use the extinguisher. There is no time to read directions during an emergency.
- The extinguisher must be within easy reach and in working order, fully charged.
- Some models are unsuitable for use on grease or electrical fires.

Notes

.....

.....

.....

.....

.....

.....

.....

.....

.....

.....

.....

.....

.....

.....

Select Your Extinguisher

Choose your extinguisher carefully. A fire extinguisher should bear the seal of an independent testing laboratory. It should also be labeled as to the type of fire it is intended to extinguish.

The extinguisher must be large enough to put out the fire. Most portable extinguishers discharge completely in as few as eight seconds.

Classes of fires: There are three basic classes of fires. All fire extinguishers are labeled with standard symbols for the classes of fires they can put out. A red slash through any of the symbols tells you the extinguisher cannot be used on that class fire. A missing symbol tells you only that the extinguisher has not been tested for use on a given class of fire.

Class A: Ordinary combustibles such as wood, cloth, paper, rubber, and many plastics.

Class B: Flammable liquids such as gasoline, oil, grease, tar, oil-based paint, lacquer, and flammable gas.

Class C: Energized electrical equipment including wiring, fuse boxes, circuit breakers, machinery, and appliances.



Notes

A series of horizontal dotted lines for taking notes.

Annexure V

Training Agenda

Time	Session	Methodology
Day 1		
9.00am - 9.30am	Registration of participants	
9.30 am- 10.00am	Welcome and Introduction	
10.00am- 11.30 am	Pre Test..... Pre-test Assessment	
11.30am-11.45 am	TEA BREAK	
11.45am-1.15pm	Overview of training course Immunization Programme in India- Equipments, Transport & Handling How to store vaccine safely in a cold room. (Air throw, condensation-defrosting water, distance from wall to allow air flow, etc. Preventing Vaccine Freezing ...Video	PPT Presentations, Video
1.15pm-2.15pm	LUNCH BREAK	
2.15pm-3.45pm	Temp Monitoring & Alert Systems, Recording Graphic Chart Recorders and data loggers devices How to maintain Chart recorders/ WiFi devices (Replace battery, Ink, Chart) Temperature mapping in WIC/WIF. Graphical analysis.	PPT Presentations & [Demo]
3.45pm-4.00pm	TEA BREAK	
4.00pm-5.30pm	Equipment care & vaccine storage & safety How to look after Cold Room + contingency planning during transport/ storage failure	PPT Presentations
Day 2		
9.30 am- 10.00am	Recap of the Day 1	Interactive session & open discussion.
10.00am-11.30 am	How refrigeration cycle works... Refrigeration Components & Their Functions	PPT Presentations, VIDEO, Demo
11.30am-11.45 am	TEA BREAK	
11.45am-1.15pm	Common problems, issues and impact of failure of Refrigeration Components [Demo]	PPTs, Interactive session, Open Discussion.
1.15pm-2.15pm	LUNCH BREAK	
2.15pm-3.45pm	Electrical basics Electric Control, Components & Their Functions. Introduction to Principle of operation & function of Servo Controlled Voltage Stabiliser.	PPT Presentations
3.45pm-4.00pm	TEA BREAK	
4.00pm-5.30pm	Common problems, issues and impact of failure of Electrical Components	PPT Presentations & discussions.

Time	Session	Methodology
Day 3		
9.30 am- 10.00am	RECAP DAY-2	Interactive session & open discussion.
10.00am-11.30 am	Introduction to different WIC/WIF models used. Description of components used for Mono block type Cooling units & its Detail Technical Specifications Refrigeration Circuit Electrical Circuit Diagram illustration	PPT Presentations
11.30am-11.45 am	TEA BREAK	
11.45am-1.15pm	Description of parameter settings & Wiring of different Temperature Controllers Master log / DTC-Dixell / CRC-1200	PPT Presentations & Hands-on Practical Demonstration
1.15pm-2.15pm	LUNCH BREAK	
2.15pm-3.45pm	Hands -on - Continued + discussion on differences	Interactive session & open discussion.
3.45pm-4.00pm	TEA BREAK	
4.00pm-5.30pm	Block Diagram and explanation of AMF, Wiring Diagrams Principle of operation & function of AMF panel Principle of operation & function of the components used in AMF panels Power back up- Generator Earthing	PPT Presentations
Day 4		
9.30 am- 10.00am	RECAP DAY-3	Interactive session & open discussion.
10.00am- 11.30 am	WIC/F Installation Facility assessment and Site Preparation Pre installation Checklist for WIC/F Installation / Proper Installation procedure List of spares that should be kept with each WIC-WIF installation. (Controller & sensor, contactors, relays, switches, heater, solenoid, pressure switch etc.	PPT Presentations.
11.30am-11.45 am	TEA BREAK	
11.45am-1.15pm	Tools, items & consumables required for installation WIC-F Commissioning Tests Verifying Installation & performance WIC/F Preventive Maintenance checklist	PPT Presentations
1.15pm-2.15pm	LUNCH BREAK	

Time	Session	Methodology
2.15pm-3.45pm	GENSET Installation..... Pre installation Checklist Installation Proper Installation procedure Testing performance & verifying installation & Review of Commissioning Reports	PPT Presentations
3.45pm-4.00pm	TEA BREAK	
4.00pm-5.30pm	Fitting Electrical Panel, Accessories, checklists for performance test Inter connection of components... Description of parameter setting for different make AMF panel controller. i.e. Woodward/EC2/Tecno Elettra Electrical Circuit Diagram illustration	PPT presentations & Hands on. Demo
Day 5		
9.30 am- 10.00am	RECAP DAY-4	Interactive session & open discussion.
10.00am- 11.30 am	Common Problems & diagnosis - Tools/ Testers and referring circuit diagrams Split cooling units, Cooling unit component layout- Refrigeration Circuit /Electrical Circuit	Discussion & On job practical PPT Presentation.
11.30am-11.45 am	TEA BREAK	
11.45am-1.15pm	Practical Fault Finding on 3-4 different Kits one by one Kits are for..... Digital Temperature Controllers/Cooling Units AMF panels/Cold Room Panels/Alarm Units	On job practical
1.15pm-2.15pm	LUNCH BREAK	
2.15pm-3.45pm	Practical fault Finding Contd + Discussions & feedback Contd- Repairs & maintenance -- What if questions i.e. if compressor is not running, but temperature inside are high, what could be wrong? Questions & answers contd---If controller malfunctions	PPT Presentations, Interactive sessions & open discussion
3.45pm-4.00pm	TEA BREAK	
4.00pm-5.30pm	Quality of repair + Contingency Planning Toolkits and Service Kit (Gas Charge Analyser, Hoses, Manometer etc) - What is required for repair and their correct use. What to check after repair- To say that repair is successful/ good quality.	PPT Presentations, Open Discussion. Presentation by different groups on differences & logic of the design.

Notes

A large rectangular area with a light gray background, containing numerous horizontal dotted lines for writing notes.

Annexure VI

Indicative cold room area of WIC 30 CBM

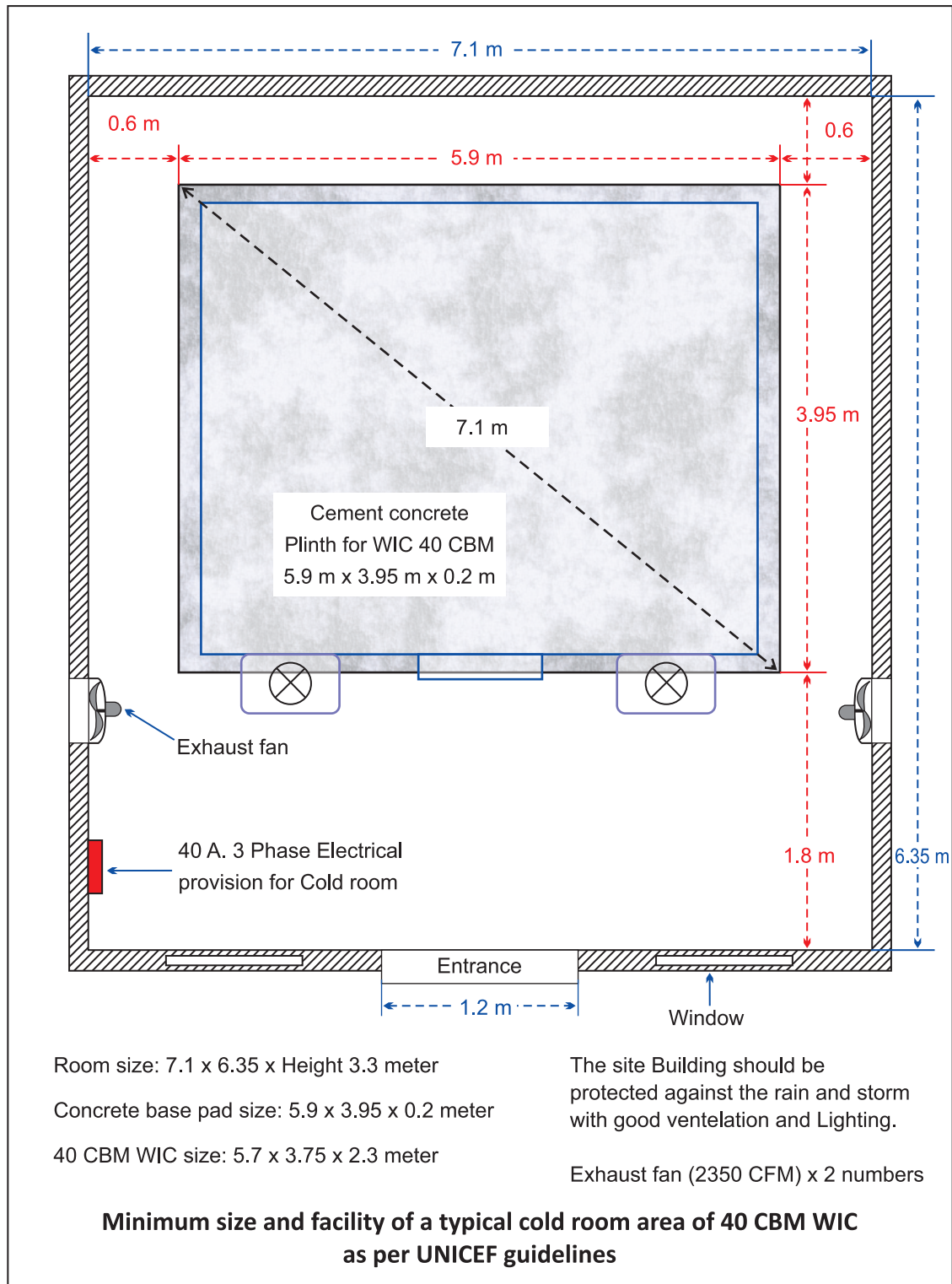

Annexure VII

Indicative cold room area of WIC 40 CBM

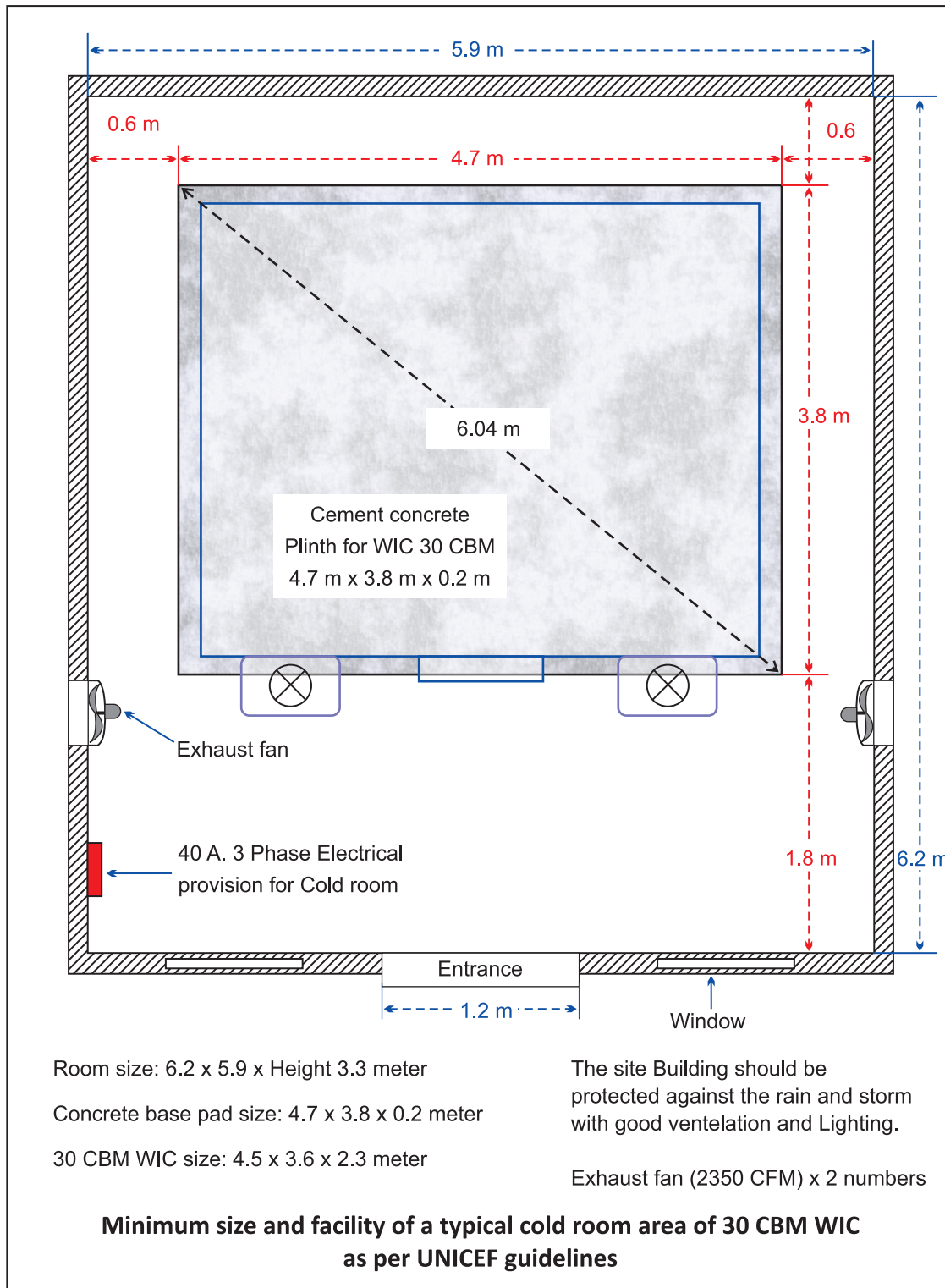

Annexure VIII

Indicative 20 m³ capacity WIF Installation drawing

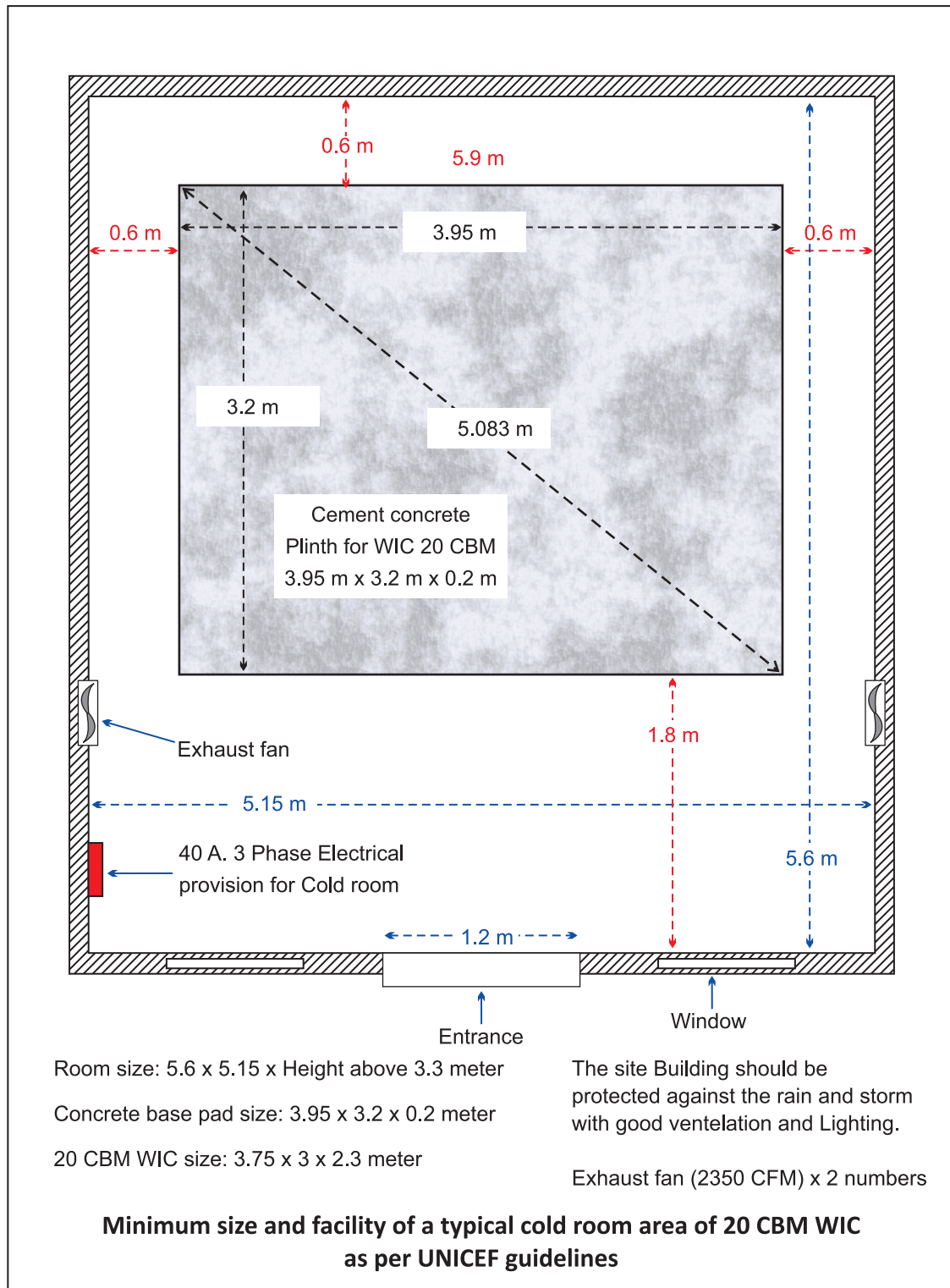

Annexure IX

Indicative floor plan of a model RVS/DVS

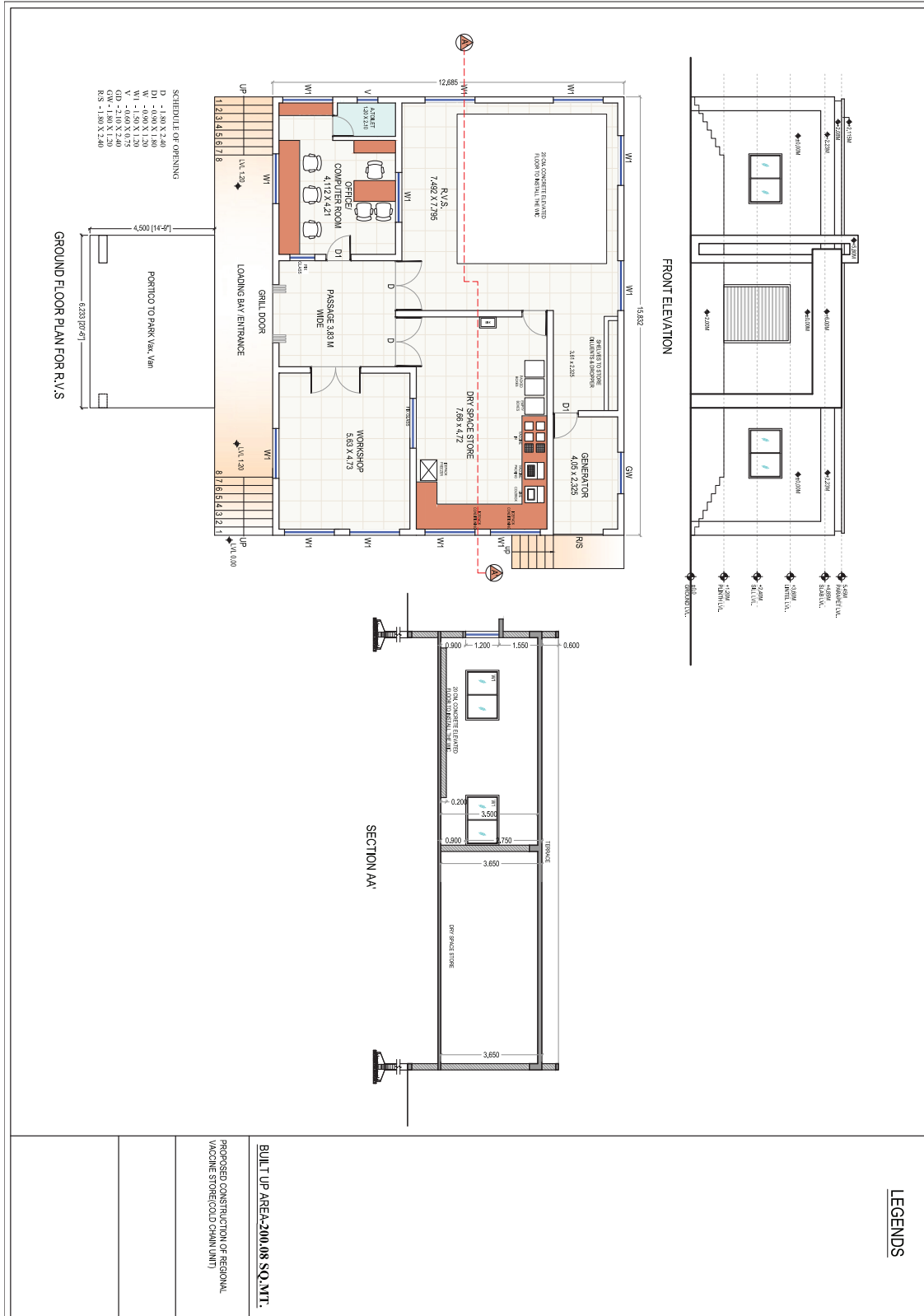



Developed by UNICEF India Country Office for Ministry of Health & Family Welfare, Government of India